

**FytoArbour/Greenwall
Automated Public
Toilets**

FytoGreen



Who are Fytogreen

The team at Fytogreen assist Australian and international developers, architects and landscape architects seeking to create beautiful, environmentally sustainable gardens integrated into built structures.

Fytogreen success and technical know-how provides our clients, architects and designers a rapid interchange of experience that has developed into a cost effective, ecologically sustainable solution for greening the built environment.

Biophilic design should be a core strategy for any designer or architect looking to future developments. Strategic and mindful design that (re)connects humans with nature does not just improve the habitability of spaces — it transforms them into rejuvenating, inspiring places that support enhanced health, productivity and learning for all.



Fytowall Green Wall
Melbourne St, Brisbane



Roof Garden
Bendigo Hospital, Vic



All contents of this document are supplied from extensive years of experience designing and constructing gardens on built structures here in Australia. All technical aspects of this documentation are considered intellectual property of Fytogreen.



Fytogreen History

A track record of success

Fytogreen was such a dream to work with, you took so much of the risk out of the project. The green roofs and the central green wall is looking fantastic!

- James Birrell
Director, Place Design Group

Fytogreen Australia Pty Ltd was founded in February 2002, when the company became the established licensee in Australia, following on from 23 years of development by Fytogreen originators in Europe.

Over the past 18 years, Fytogreen has become the industry leader & innovator in horticultural technologies.

We are a research focused, design & construct supplier of vertical gardens, roof gardens, green facades, planter boxes and all of Fytogreen's design and project management team has extensive experience in the industry

Fytogreen have completed more than 350 successful vertical garden projects, encompassing over 8,000m² of living walls within Australia and international locations.

Fytogreen have also supplied proprietary roof garden media components to approximately 770,000m² of roof gardens and 75,000m² of design and construct extensive roof gardens throughout Australia. Fytogreen has worked with the majority of Tier 1 and Tier 2 construction builders, either directly or indirectly in the capacity of a sub-contractor.

Our established knowledge library created over many years of collaboration with horticultural experts allows Fytogreen a rapid interchange of experience, problem solving, commercial and technical know-how, which has greatly enhanced our effectiveness and ability to service our clients' needs.

Fytogreen is Australia's leading supplier of vertical gardens and green roofs, delivering Australia's tallest indoor green wall at Tower Four, Collins Square in Melbourne's CBD, as well as the largest green roof in the Southern Hemisphere at the Victorian Desalination Project.

[CLICK HERE TO READ THE FYTOGREEN CAPABILITY BROCHURE](#)



FytoCylinders
QUT, Brisbane

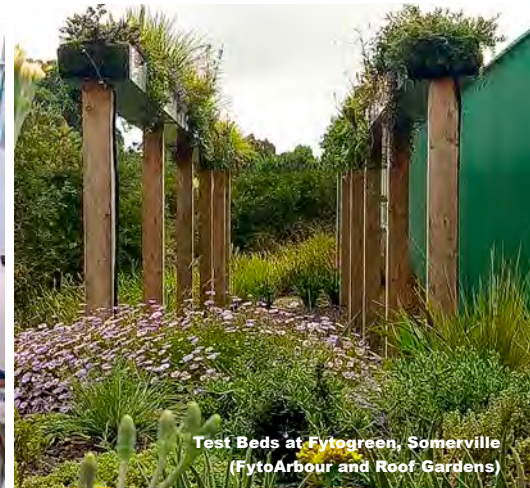

Test Beds at Fytogreen, Somerville
(FytoArbour and Roof Gardens)

Greening the Built Environment

www.fytogreen.com.au



City of Sydney Queries – QMS Media Automated Public Toilets

‘Green Roof and Green Walls

Council’s landscape officer has reviewed the submitted application and considers that there is insufficient information to demonstrate the green roof and green wall system are feasible. It is required that a green roof and wall design be submitted, confirming:

- *If a proprietary system or bespoke design*

The green roof is a hybrid proprietary system from Fytogreen – Fytoarbour Fire Compliant modules, that are 200mm deep and either 250mm W or 500mm W, depending on the location on the roof. The design is fit for purpose and has existing precedents in Sydney with 60 Martin Place, as it provides the following attributes – lightweight at a maximum of 50kg/lm and the drainage water is clear. (please find attached brochure)

The greenwall system is the proprietary Fytofelt Fire Compliant system with 3,000m² of this system in Australia, as a new product type to meet the industry requirements. Fytogreen have designed and installed in excess of 8,000m², so have considerable experience to call on. (please find attached brochure)

- *Overall green roof/green wall soil depth, soil media specification, drainage and irrigation design*

The modular green roof is 200mm deep (completely soilless, so 98% of the volume is usable for root development and upto 30lts per lm of plant available water is within the system. Transferring that in a well designed engineered soil with a total porosity of 62%, you have an equivalent depth of 322mm.

The media is our Polyester B1 water absorbent felt that is used on our Fytofelt greenwalls, 98% pore space, inert, UV stable and ideal as a lightweight hydroponic media.

The irrigation is a double dripline of Netafim AS, 100mm emitter spacing and an emitter flow rate of 0.6lts/hr, so the irrigation is very uniform and the water absorption of the felt, very strong.

The irrigation system is a pre-assembled plug in solution comprising of Dual check valve/Static 30 psi pressure reducer/Hunter Node Bluetooth irrigation controller that will irrigate the both the greenwall and the Fytoarbour at the same time on a typical 4 irrigation events per day at 4-5 minutes per event. Both systems have enough moisture retention for the system to fail for 5 days, prior to plant stress becoming evident.

The greenwall system is 90mm deep plus foliage and sits in a recessed space of 180mm

- *Planting design and species list*

Plant designs have been submitted and approved and are currently in the pre-growing stage, so not sure why this is being clarified again.

- *Wall and roof fixing details [to be supplied by others]*

- *How the green roof and walls will be accessed and maintained post construction contract*

The greenwall is a walk up at a maximum height of 1.8m, so a small platform ladder will be required to get to the very top row.

The Fytoarbour on the roof will be accessed by an external ladder by Fall Restraint Rope ticketed operatives, attaching to a certified anchor point to attend to any required plant maintenance.

- *Demonstrate resolution of the design and an alternative should the green wall fail **Street Trees***

In both options proposed, they are proven proprietary systems, that can easily have plants replaced as and if required, ably supported by Fytogreen’s resident Sydney maintenance team.

4

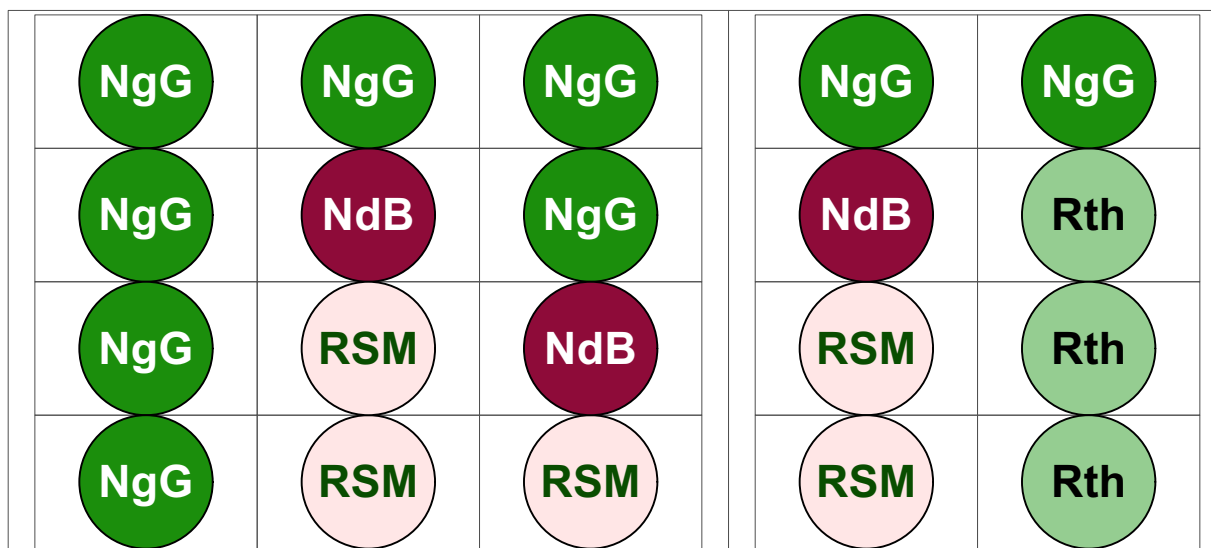

3



2

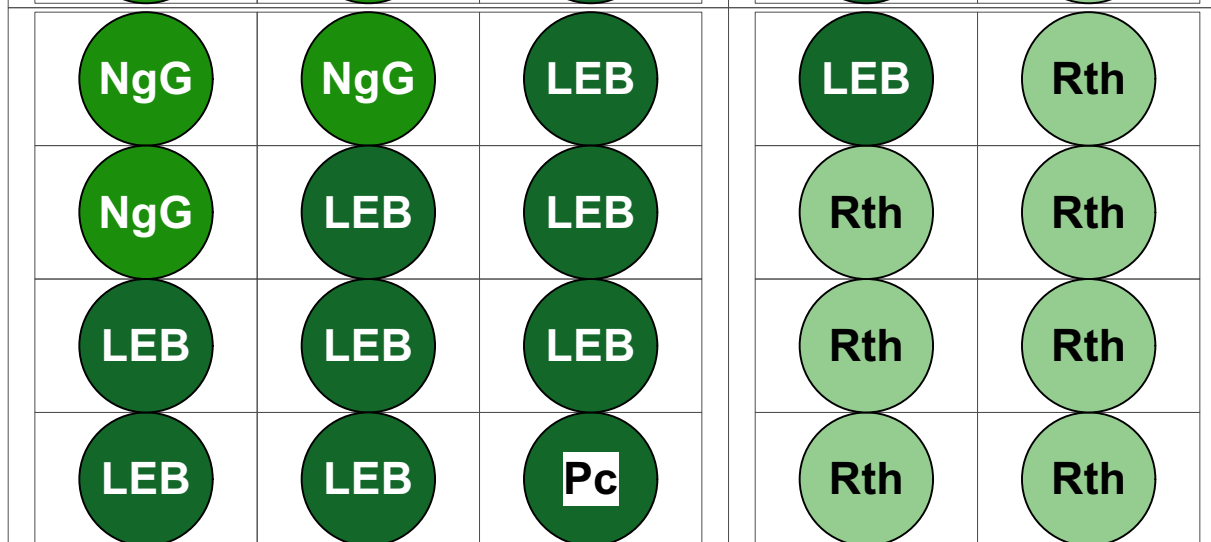

1

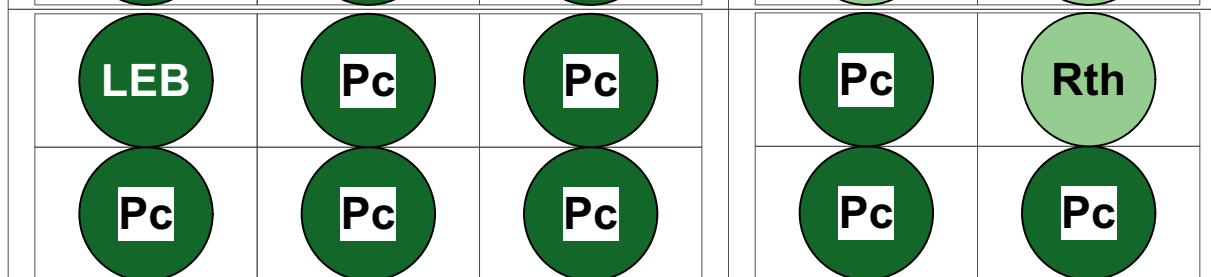

A

B

Plant Code	Latin Name	Quantity
LEB	<i>Lomandra 'Evergreen Baby'</i>	17
NdB	<i>Nandina domestica 'Blush'</i>	3
NgG	<i>Nematanthus 'Goldfish'</i>	20
Pc	<i>Plectranthus ciliatus</i>	9
RSM	<i>Rhaphiolepis 'Snow Maiden'</i>	6
Rth	<i>Rhipsalis teres v. heteroclada</i>	15

2

Planting Schedule

Scale: 1:20

Lomandra 'Evergreen Baby'



Nandina domestica 'Blush'



Nematanthus 'Goldfish' (Orange)



Plectranthus ciliatus



Rhipsalis teres f. heteroclada



Rhaphiolepis 'Snow Maiden'



NOTE

This planting plan is indicative only of a potential full sun vertical garden in Sydney. In-depth assessments of inherent exposures and refinement of species selections are required to ensure sustainable outcomes are generated.

Species selections and are not akin to terrestrial gardens, rather placing an emphasis on epiphytic and lithophytic species with inherently evolved adaptations to survive and thrive on the vertical plane.

This is a hybrid selection of trialled and tested species inclusive of a minority terrestrial species.

Species selection and array go hand-in-hand pending function.

PROJECT

Grimshaw Str - Indicative Planting for Sun
ADDRESS
Grimshaw Str, Sydney, NSW

CLIENT

QMS Media Pty Ltd
DRAWING

Planting Plan

Fytogreen

FYTOGREEN PROJECT # 100575FF
DATE 16 Aug 2021
3 Webbs Lane
Somerville VIC 3912
Phone: 1300 182 341
Fax: 03 5978 0744
Email: info@fyto-green.com.au
DRAWN ECvZ

1

Planting Plan

Scale: 1:8.5

Experience

Fytogreen Australia have been involved in many of Australia's innovative and complex greening projects, meeting technical challenges to enhance nature's expression to the built environment.

To view our project gallery visit:
www.fytogreen.com.au/projects



Australian Tallest Indoor Green Wall

52.9m high (463m²)

Tower Four, Collins Square
727 Collins St, Melbourne

[Read More](#)



Southern Hemisphere's Largest Roof Garden

27,000m²

Victorian Desalination Plant
Wonthaggi, Victoria

[Read More](#)



Multi Award Winning Caroma on Collins

282m²

Caroma Showroom,
37 Collins St, Alexandria NSW

[Read More](#)

Greening the Built Environment

www.fytogreen.com.au



60 Martin Place . Sydney

Fytogreen



78 m2 / 384 lm
FytoArbour Living Beams

Location Levels 4 & 30, 60 Martin Pl, Sydney
Client Regal Innovations / Lendlease
Developer Investa
Landscape Architect HASSELL
Design & Install Fytogreen Australia
Maintenance Fytogreen Australia
Completion July 2019



Greening the Built Environment

www.fytogreen.com.au



Workshop . Harris St, Sydney

Fytogreen

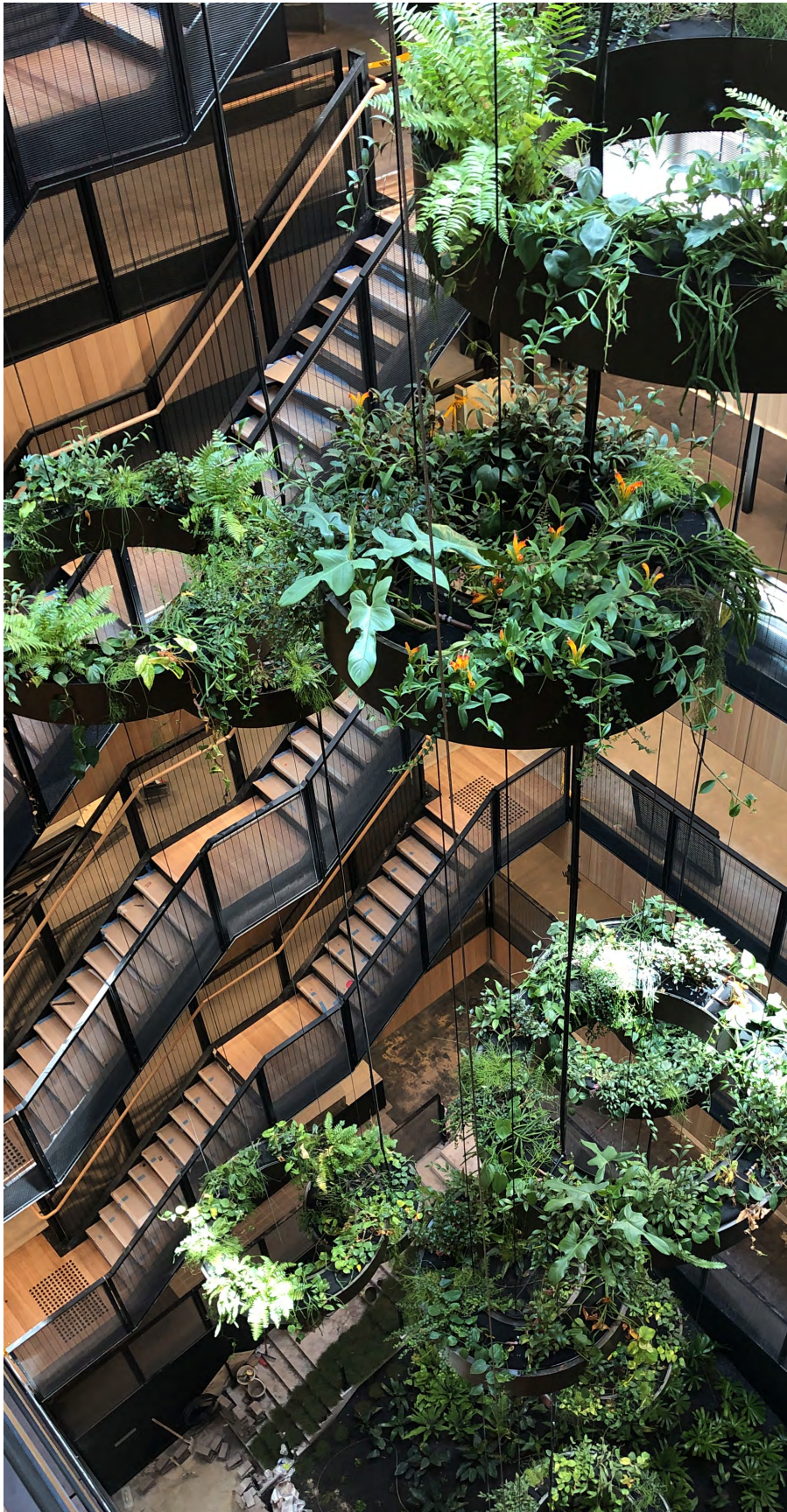

Another
1st for
Australian
Greening

**95LM Circular FytoArbour
Levels 1-7 Indoor Atrium**

Location	21 Harris St, Pyrmont, Sydney
Client	Milligan Group
Builder	Icon
Architect	Bates Smart
Design & Concept	Tensile
Design & Install	Fytogreen Australia
Maintenance	Fytogreen Australia
Completion	February 2020



Greening the Built Environment

www.fytogreen.com.au





33 Im
FytoArbour Indoor Atrium

location	150 Oxford Street, Collingwood
client	Academy of Design
architect	Gray Puksand
project builder	Renasant
design & install	Fytogreen Australia
completion	February 2018



Private Residence . Doncaster



FytoArbour roof garden growth at time of installation



24.6 lm - 3 x 8.2m FytoArbour Super Lightweight Roof Garden

Location	Doncaster, Victoria
Client	Owner
Design & Install	Fytogreen Australia
Completion	June 2020

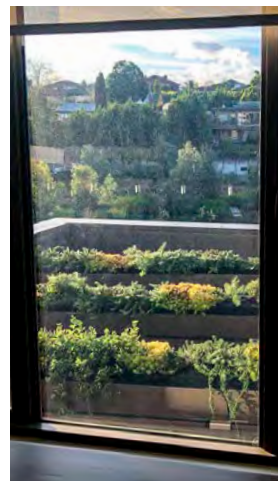

Fytogreen's FytoArbour system has become an innovative greening solution for supplying a roof gardens on a Klip-lok roof system.

The FytoArbour is only 25kg per LM in saturated weight, and is installed with non-penetrating fixing components.

It is the perfect solution for greening an existing metal deck roof that is not suitable for an extensive roof garden.

Greening the Built Environment

www.fytogreen.com.au



Benefits of Green Infrastructure

Green infrastructure improves the quality and livability of urban environments, increasing their adaptability and resilience to climate change. The benefits of green roofs, walls and facades flow to individuals, communities and organisations. Some of these benefits are discussed below.

Improved air quality

Green infrastructure results in improved urban air quality due to the increased presence of greenery in cities, which remove pollutants from the air. Green walls can remove up to 40% NO₂ (nitrogen dioxide) and 60% PM₁₀ (particles with a diameter of 10 micrometers or less) from the air at street level.⁷ They also sequester carbon dioxide (CO₂) in plant biomass and substrate.

Improved water quality

Green infrastructure can slow and clean rainwater run-off from buildings, improving water quality and minimizing the effect that polluted run-off has on natural waterways.

Biodiversity

Green roofs, walls and facades provide additional space for living organisms to find food and shelter, increasing urban biodiversity.

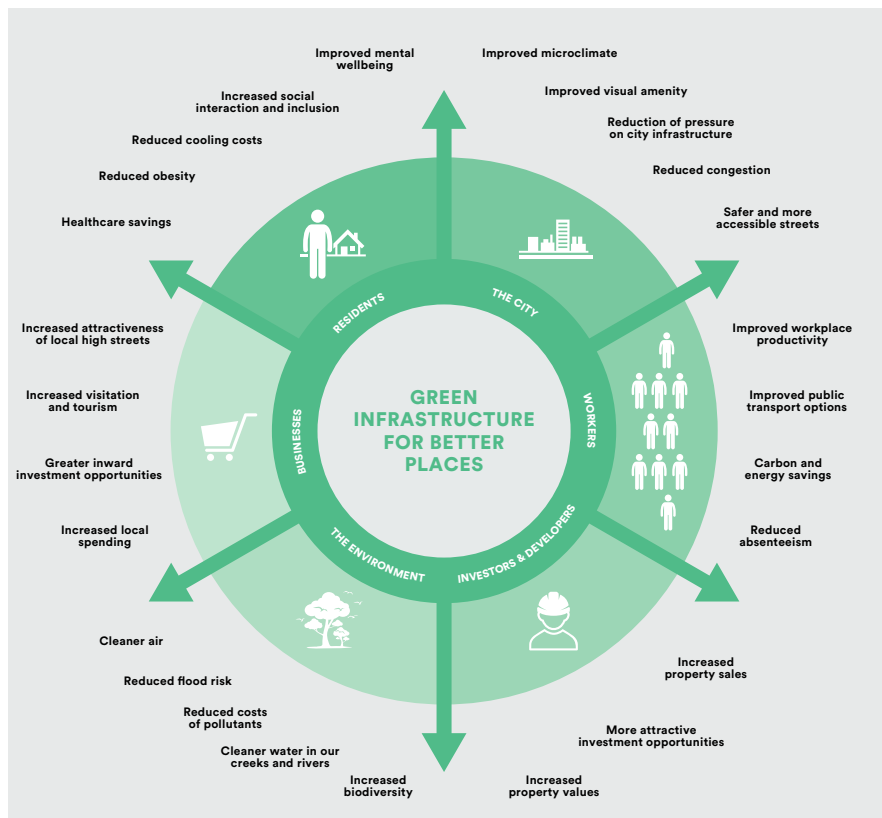

Benefits of Green Infrastructure

Thermal and acoustic comfort

Green roofs, walls and facades protect buildings from outside noise, creating healthier and peaceful indoor environments.

Green infrastructure also mitigates the “Urban Heat Island” (UHI) effect, which refers to an urban micro-climate that is significantly warmer than surrounding areas due to the lack of green cover and the prevalence of hard surfaces that absorb and radiate heat.

Improved health, wellbeing and productivity

The combined effect of the above benefits contributes to improved health and wellbeing for occupants and urban city dwellers. Research has also shown that there are psychological benefits and increased rates of productivity when humans are surrounded by elements from the natural environment.



**Bespoke
Ecological
Sustainable
Greening
Solutions**

Fytogreen work collaboratively with our clients; home owners, architects, landscape architects or project consultant teams, utilizing our extensive technical know-how to deliver unique, sustainable greening solutions to fit any project vision.

We offer the widest range of greening solutions on the market, with multi-dimensional systems that increase the diversity, quantity and density of biophilic design and the capability and industry know-how to create brand new solutions when required.

The standard Fytogreen range includes...



FytoWall
A soil-less panel vertical garden system suitable for commercial indoor and outdoor applications.



FytoFelt
A pocket green wall system suitable for commercial and residential projects Available as design / install or DIY.



FC FytoFelt
A fire-compliant (AS1530.3-1999) pocket system green wall system for indoor or outdoor applications.



Curves, Columns & Cylinders
Curved walls, suspended cylinders or columns rising from floors, we can create vitally any size or diameter.



FytoArbour
Ultra-lightweight, self-contained hydroponic garden that can be mounted above the ground.

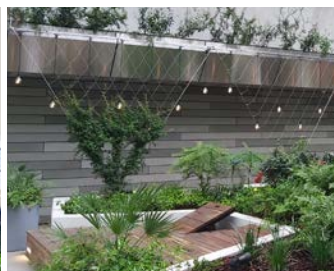

Green Facades
Cost-effective vertical greening utilizing climber and creeper plants on wires and cables.



Pre-Grown Green Facades
This system provides great foliage cover at installation, instead of waiting up to 2-3 years for coverage.



Roof Gardens
Intensive, Extensive and sloping sustainable living roofs for residential and commercial projects.



LLDPE Planter Boxes
Fytogreen's range of LLDPE planter boxes provide a UV stable, flexible container for architectural greening.



Custom Planter Boxes
Fytogreens extensive range of custom planter boxes are suitable for nearly any indoor or outdoor application.



Floating Wetlands
Designed to vegetate water bodies for aesthetics, water clarification, safe habitat or water rehabilitation.



Horticultural Maintenance
Our specialist elevated horticultural maintenance service is recommended for all our unique greening projects.

Fytogreen also offers a unique capability to design and create tailor made bespoke greening solutions to suit your projects needs.

Fytogreen Australia Greening the Built Environment

www.fytogreen.com.au



Summary of Responsibilities of Fytogreen

The following is the complete list of the responsibilities of Fytogreen, which are included in the 'cost of works':-

MISC.

- Provide up to eight (8) man hours of travel and attendance on design and other meetings and visits, review of any contract documentation, shop drawings, site inductions, etc.

ARCHITECTURAL AND DESIGN

- Provide you with advice as to plant species suitable to your conditions and provisional availability.
- Assist you with your design.
- Final design approval, including species selection and layout.

OFF-SITE

- Source necessary plants from third parties, subject to availability.
- Cultivate the plants in the green wall growing modules.
- Prefabricate the irrigation system, with controls.

STRUCTURAL

- Provide information in relation to structural attachment options.
- Supply and installation of stainless steel brackets.

HYDRAULICS

Supply and installation of the following.

- Control box. (Actual size: 700mm high x 500mm wide x 300mm deep) containing
- Electrical irrigation controls and,
- Pressure reduction valve.
- Nutrient dispenser.
- Irrigation lines within the green wall.

ELECTRICAL

Supply and installation of the following:

- Control box, containing 'hydraulics' and, irrigation and nutrient controller.
- Low voltage control wiring, (data cabling) between control box and green wall and alarm(s) in conduit provided by others.

INSTALLATION

- Not to proceed until we have received from you a completed 'Certificate of Readiness'.
- Delivery of all components.
- Installation and commissioning of green wall.

MAINTENANCE

(Refer to our maintenance specification for full list and details.)

- Maintain the garden for the initial maintenance period.
- Offer an ongoing maintenance agreement at your cost.



Summary of Responsibilities of, and Works by Others

The following are the responsibilities of others and shall be provided and/or carried out by others, in a timely manner, to the approval of and a no cost to Fytogreen:-

MISC.

- Obtaining all necessary approvals.
- Compliance with authorities requirements and timely advice to us in relation to same, where they relate to our responsibilities.
- Advising us if windows that are intended to provide growing light to the vertical garden have 'solar glazing' and if so, what fraction of light is affected and by how much.
- Advise us of any external sunscreens that exist or may be planned.

ARCHITECTURAL AND DESIGN

- Species selection and design array, subject to our advice regarding sustainable species for conditions, and placement.
- Design, supply and installation of Fascia surrounds and other trims.

STRUCTURAL

(Refer to 'structural responsibilities' herewith, for more details.)

- Provision of an adequate host wall.
- Fixing of subframe to host wall.
- Enclosure, if surface mounted, complete with fascia and architectural trims.
- Certification that the host wall subframe and fixings are adequate. (Certificate of Readiness.)

HYDRAULICS

- In relation to supply, installation and/or long term maintenance, in accordance with the green wall hydraulics specification, the requirements of authorities and to the satisfaction of the green wall contractor:-

Provision of:-

- Location and space for control box and or boxes and access for maintenance of controls and all hydraulic components.

Supply, installation and long term maintenance of:-

- Secure, continuous, uninterrupted water at required pressure.
- Water supply at control box, for connection of irrigation.
- Non-return valve and or valves.
- Drainage tray to collect irrigation run-off, connected to a gravity drainage system or a pump-out drainage system.
- Pipework for irrigation water, from control box to green wall, if required to be installed prior to installation of the green wall. (e.g. built-in out of sight.)

In relation to any interruption to the water supply

- Action in accordance with requirements set out in the 'FytoWall hydraulics specification'.

ELECTRICAL

- In relation to supply, installation and/or maintenance, in accordance with the 'FytoWall Electrical Specification', the requirements of authorities and to the satisfaction of the FytoWall Contractor:-

Provision of:-

- Location and space for a control box, visual alarm and/or an auditory alarm and access for maintenance of them.
- Either a conduit with a draw wire, running from the Fytowall to the control box location, for data cabling, or data cabling pre-installed. Ditto for alarms.

Supply, installation and maintenance of:-

- Continuous, uninterrupted electrical power.
- Grow lights and time controls, if required.
- General illumination as required.
- Switchboard and circuit breakers.
- General power outlets.
- Telephone connection, (if required for alarm).
- If specified elsewhere, a pump-out drainage system.
- 'Drain blocked' alarm, if required by client.

In relation to any interruption to the electrical power supply:-

- Action in accordance with requirements set out in the 'FytoWall electrical specification'.

INSTALLATION

(Refer to our specifications and general terms and conditions for additional responsibilities.)

- Parking for Fytogreen's delivery truck for unloading adjacent the works.
- In the immediate works area, a sorting area, unimpeded access, working space, lighting, fresh air and power within 15 metres.
- Amenities on site for our personnel.
- Secure overnight storage of components, tools and equipment if required.

MAINTENANCE

(Refer to our maintenance specification for full list and details.)

- Select and enter a suitable ongoing maintenance agreement.
- Ensure uninterrupted lighting, electricity and water supply.
- Ensure plants are growing well and getting sufficient water and light.
- Inform us promptly if
- Alarm (if installed) activates.
- Wall appears dry in any section.
- Irrigation was disrupted for longer than 36 hours.
- Date and time on control board is wrong or flashing. (e.g. after an interruption to power supply or an electrical storm.)
- There is any planned interruption to lighting, water or power supply.
- There is any abnormality, malfunction or concern.



Fytogreen General Terms and Conditions

If you have questions about any of the conditions below, please contact Fytogreen.

WHAT IS INCLUDED - The whole of the submission herewith, including the terms and conditions hereinafter, together form Fytogreen's submission for the proposed works. Unless alteration is specifically agreed to in writing by a director of Fytogreen, the whole of the submission shall be deemed to be included in any order issued by the Client and shall form part of any contract entered into as a result of, or following, this submission and shall take precedence over any other condition, including condition that implies negation of this condition, other than as included elsewhere in Fytogreen's submission. Any alterations & additional requirements (plus margin) shall be at Client's cost. This page is subordinate to the remainder of the submission.

PERIOD OF VALIDITY - Prices and rates are firm for 30 days only.

GOODS & SERVICES TAX - GST will be added to submitted prices and rates.

DEPOSIT - Unless otherwise stated, a deposit of 40% is required.

TERMS OF PAYMENT - Balance in full on completion COD

RETENTION SUMS - The Client shall not withhold any retention.

NON-PAYMENT OF PROGRESS CLAIMS - Client shall not be entitled to withhold payment from Fytogreen, on the basis that it has not received payment from a third party.

INTEREST - Should any amount claimed by and due to Fytogreen be withheld in contravention of this agreement and/or remain unpaid after the due date, an administration charge of \$100. per month shall apply & interest on the overdue amount shall be payable to Fytogreen, from & inclusive of the day following due date, up to the date on which the payment is received, at rate of 15% p.a.

CERTIFICATION AND WARRANTIES - All warranties applicable to the works are specified in writing elsewhere in Fytogreen's submission. No other warranties shall apply. No certification/warranties shall be issued/take effect unless all payments are made to & received by Fytogreen within "Terms of Payment" set out herein.

SPECIAL ALLOWANCES - Special allowances for labour (e.g. a Site Allowance) are not included. Should Fytogreen be required by Client or third party, to pay any allowances to its personnel, it shall be reimbursed by the Client, at cost plus 10%.

DAYWORK & SCHEDULES OF RATES - Where works are carried out on a Schedule of Rates/Day-labour/material basis, the Client shall be responsible for requesting, checking and signing Fytogreen's record sheets daily. Any disputes must be recorded thereon. Once recorded and signed, these records shall not be contested by the Client and any payment due, shall be in accordance with such records. Should the Client fail to sign these records (noting any dispute if necessary) for any reason, such records shall nevertheless be accepted as a true and fair record of time and materials expended.

SITE ACCESS & DELAYS - The Client shall be responsible for providing Fytogreen with safe, suitable & timely access to the site & work area, for material, personnel & equipment. Such access shall be clear & unimpeded. Fytogreen shall be entitled to reimbursement for all costs and expenses incurred, as a result of access or any delays in the progress of the works beyond its control.

HOURS OF WORK - Unless set out elsewhere, this submission is based on a "38 hour week". The works shall be carried out between the hours of 0700 and 1700 hrs Monday to Friday. Fytogreen may, at its discretion, work additional or altered hours and/or days at no cost to the Client and with no costs being imposed on Fytogreen by the Client. Additional or altered hours or days requested by the Client shall be a Variation, if additional costs are incurred by Fytogreen.

EXCLUSIONS - This submission excludes the following, which shall be the Client's responsibility and cost:-

- The obtaining and cost of Authorities' approvals/fees;
- Engineering, architectural and all other design & certification;
- Site inspection by Authorities/consultants & costs arising therefrom;
- Fytogreen costs due to Client required induction, medical, training, etc.
- The security and protection and/or removal, replacement, adjustment or repair of all finishes, fixtures, fittings, floor coverings, joinery, partitions, ceilings, furniture, goods, articles, equipment, building and services, landscaping & external works, incl. to adjacent properties;
- Waterproofing and termite protection;
- Costs arising from ground movement, instability or other unsatisfactory site, ground or structural conditions;
- All other items not specifically included (written) in this submission.

SITE FACILITIES - The following services and facilities as required by and to the satisfaction of Fytogreen, shall be provided by the Client without cost to Fytogreen, at the work site:-

- Lighting and fresh air; Cleaning and rubbish removal;
- A suitable area for setting up and operation of plant & equipment ;

RESPONSIBILITY FOR INFORMATION - The Client shall advise Fytogreen in writing, of all relevant documentation & information that may affect pricing and/or execution of the works or Fytogreen shall have the right to submit a Variation. Fytogreen shall have no responsibility or liability for any defects or shortcomings in the works due to lack of instructions/information from, or insufficient/incomplete documentation being provided by, the Client.

If its submission was prepared without a site inspection and conditions on site differ from those communicated to Fytogreen and upon which Fytogreen's price is thus based, such circumstances shall be deemed Latent Conditions, providing Fytogreen the right to submit a Variation.

INTENT AND SCOPE OF WORKS - Fytogreen's liability shall be limited to completion of the components of the scope of works described in this submission. Any implications or any end result not specifically described, is expressly excluded.

Where Fytogreen's submission includes such expressions as "Assumed", or "We have allowed/assumed/based/relied on" certain conditions, circumstances or information, any variation from such shall entitle Fytogreen to a Variation, if extra costs are reasonably incurred.

RESPONSIBILITY FOR SUPERVISION - It shall be the Client's responsibility to be available throughout the works, to answer queries, give directions and check Fytogreen's set out & levels and to ensure the suitability of the works relative to its requirements.

COMMUNICATIONS - Directions by the Client requiring alterations to the works, may be requested in writing. In the absence of other written direction, the Client shall sign a record of the instructions in Fytogreen's Site Records, when so requested. Fytogreen shall not be obliged to act on verbal directions.

AUTHORITY - The Client shall advise Fytogreen who has the authority to give directions or sign on behalf its behalf. In the absence of written advice, Fytogreen shall be entitled to accept instructions from anyone whom it deems could reasonably be expected to have such authority.

No agreement or alteration resulting in a change exceeding a value of \$500. shall be binding on Fytogreen, without prior acceptance in writing by a director.

PROFESSIONAL NEGLIGENCE INDEMNITY - Fytogreen shall not, itself or its officers, be liable for professional negligence in relation to any service it provides. Any design information or advice supplied by Fytogreen is of an advisory nature only and should not be relied upon. The Client shall be finally responsible for all design and certification and the engagement of a suitably qualified engineer is recommended.

INSURANCES - In respect of the works, Fytogreen can offer the following current insurance.

- Public Liability up to \$10,000,000 (Any increase at Client cost.)
- Prescribed Workers Compensation Insurance.

Contract Works Insurance shall be the responsibility of, and be effected by, the Client who shall provide evidence of such insurance upon request and shall in any case indemnify Fytogreen against loss or costs for any amount over \$500.00.

LIMIT OF LIABILITY - Client acknowledges that in the event of Fytogreen having failed to exercise reasonable care, Fytogreen's total liability, if any, shall be limited to the value of its works and be extinguished after expiry of twelve months from date of Fytogreen's claim/invoice, except as provided for by Statutory legislation.

DISPUTES - In the event of a dispute, the Client shall not be entitled to withhold any amount greater than the value of the portion of the works in dispute.

Unresolved disputes that arise between Fytogreen and the Client, shall be determined by arbitration before a single arbitrator in accordance with and subject to the Institute of Arbitrators Australia Rules for the Conduct of Commercial Arbitrations. Neither party shall be represented before the Arbitrator by a member of the legal profession.

ADDITIONAL CONDITIONS - The conditions of AS2124 - GENERAL CONDITIONS OF CONTRACT (Current edition) shall apply but shall not take precedence over the above conditions nor any other conditions of Fytogreen's submission.



FOR MORE INFORMATION CONTACT:

Fytogreen Australia Pty Ltd

3 Webbs Lane, Somerville, Victoria, 3912

Ph: 1300 182 341

Email: info@fytogreen.com.au



www.fytogreen.com.au

Fytogreen Australia

committed to providing BESPOKE
greening solutions for healthy,
ecologically sustainable buildings



FytoArbour Sustainable Living Beams

www.fytogreen.com.au



FytoArbour

An ultra lightweight suspended garden with endless options. Fytogreen's "living beam" brings an amazing WOW FACTOR, and is ideal for greening open spaces both internally or externally.

The FytoArbour module system is a self-contained hydroponic garden that can be suspended or mounted above the ground.

It has a dedicated automated irrigation and fertigation system. Utilizing the trough as continuous drainage, the requirements for drain outlets is also significantly reduced.

Cover Image - Pacific Fair, Broadbeach, QLD



FytoArbour Cascading
60 Martin Place, Sydney

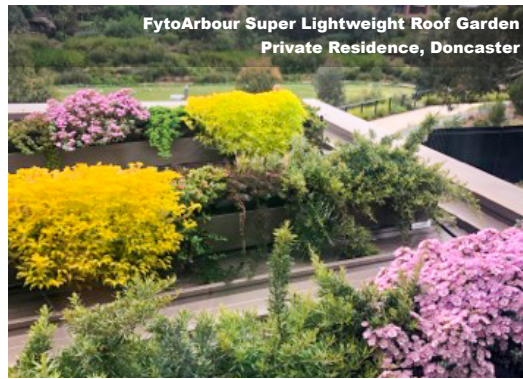

FytoArbour Super Lightweight Roof Garden
Private Residence, Doncaster

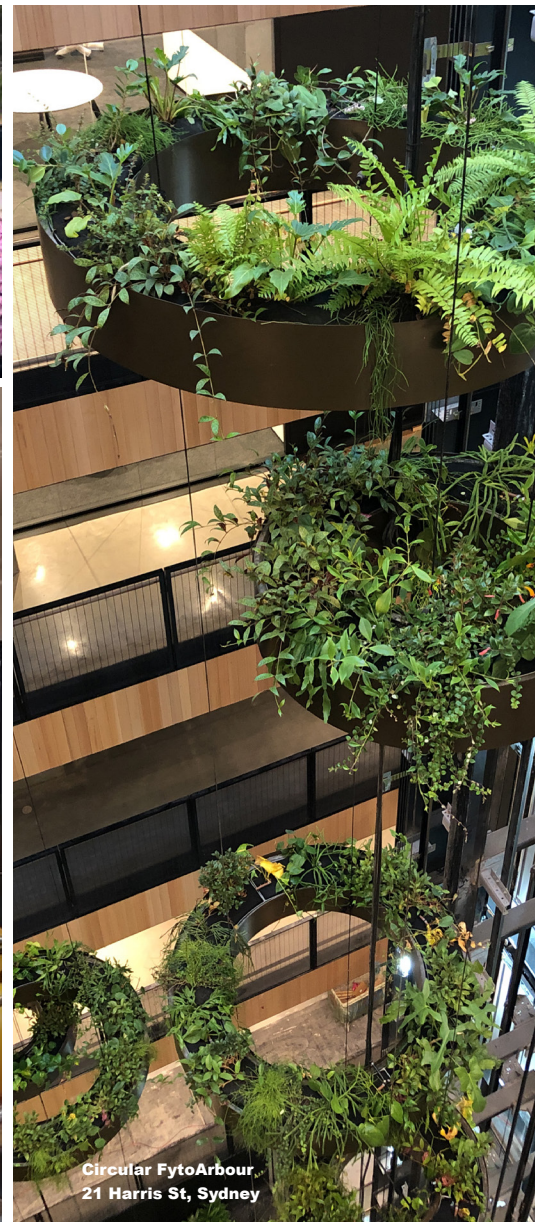

Circular FytoArbour
21 Harris St, Sydney

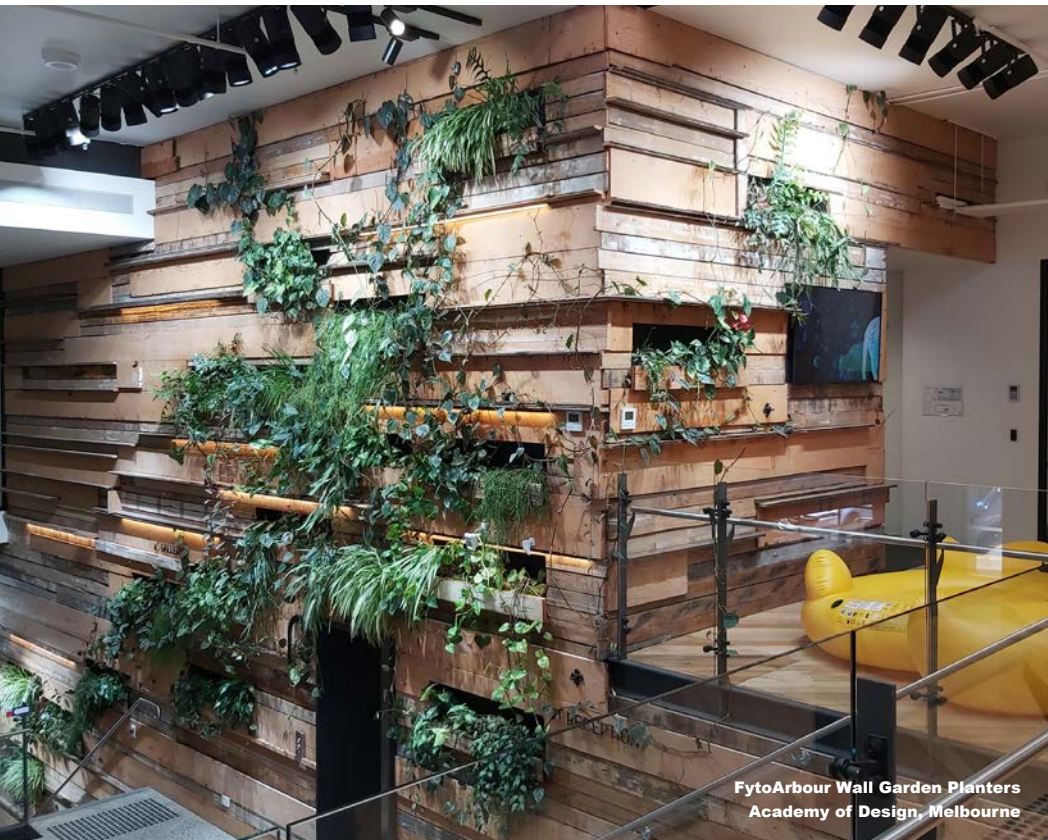

FytoArbour Wall Garden Planters
Academy of Design, Melbourne

FytoArbour Sustainable Living Beams

www.fytogreen.com.au



FytoArbour Typical Specifications

Fytogreen's standard FytoArbour modules are 1100mm long and can be placed end to end indefinitely to suit the application.

- Full saturated weight 25kg - 84kg per lineal metre.
- The containing trough will need drainage at the fallend, typically a 40mm puddle flange.
- A typical 20mm poly supply line is required to join with the 13mm Techline irrigation pipe.
- A double GPO is required near the irrigation controller and fertigation unit.

The "living beam" generates an amazing WOW FACTOR and is ideal for arbours, pergolas, atriums, lightweight roof gardens ... the possibilities are endless.

PLEASE NOTE: Bespoke length and sizes are also available.

[Click here to learn more about Fytogreen, see our latest FytoArbour projects](#)



Ultra Lightweight

Fully Saturated weight
from 25kg LM
(130 x 200mm module)



Large Species Range -

Over 20 cascading species
available to suit your desired
ascetic



**Cost effective
Greening without
compromising on space**



Suitable for Flowering species

A great opportunity to
include a 'pop' of colour

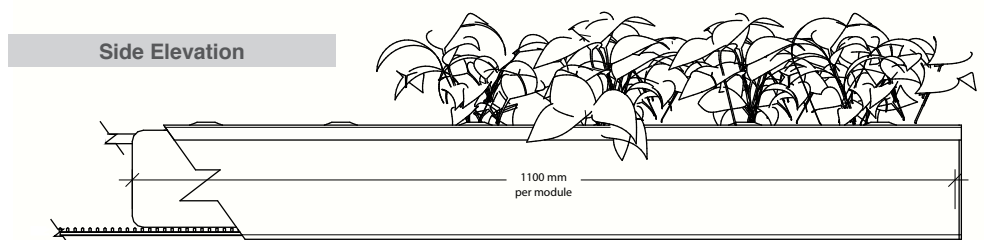

Fytogreen indoor (left) and outdoor (right) research and development FytoArbours - Head Office, Somerville.

FytoArbour Sustainable Living Beams

www.fytogreen.com.au



FYTOARBOUR - STANDARD TYPE #1

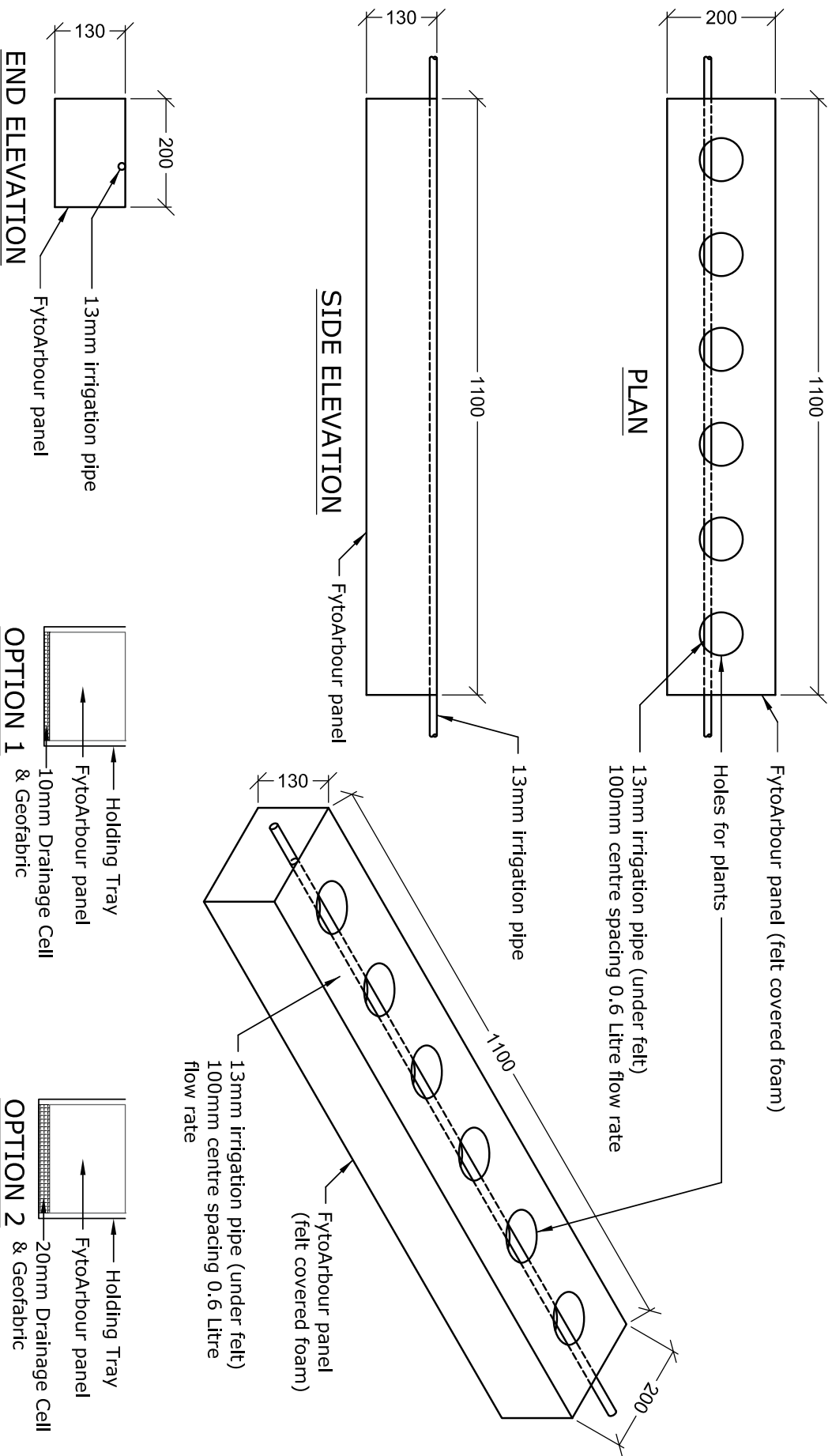

Project Title: FYTOARBOUR - 1100 long x 200 wide x 130 deep TYPICAL DETAILS		Project Number	
Date: 17/09/20	Drawing No: FA - 001	Revision: A	Drawn By: MC
Scale: 1:10	<p><small>All dimensions and levels must be checked on site and not scaled from the drawing. The drawing is subject to copyright and must not be reproduced or used in any other form without prior written permission from FytoArbour Pty. Ltd. Images shown are indicative only and may vary slightly from actual appearance.</small></p>		Checked By: GH
Rev	Date	Description	
		FYTOARBOUR - STANDARD TYPE #1 SATURATED WEIGHT INCLUDING PLANTS: 25kg/LM	
<p>FytoGreen SPECIALIST QUANTITIES - GREEN PLANTERS - SOIL SOLUTIONS FytoGreen Australia Pty. Ltd. ABN: 20 099 581 736 3 Wicks Lane, Somersville, VIC 3912 ph: 1300 182 341 fax: +61 3 5978 0744 E: info@fytoGreen.com.au www.fytoGreen.com.au</p>		Project Number	

FYTOARBOUR - STANDARD TYPE #2

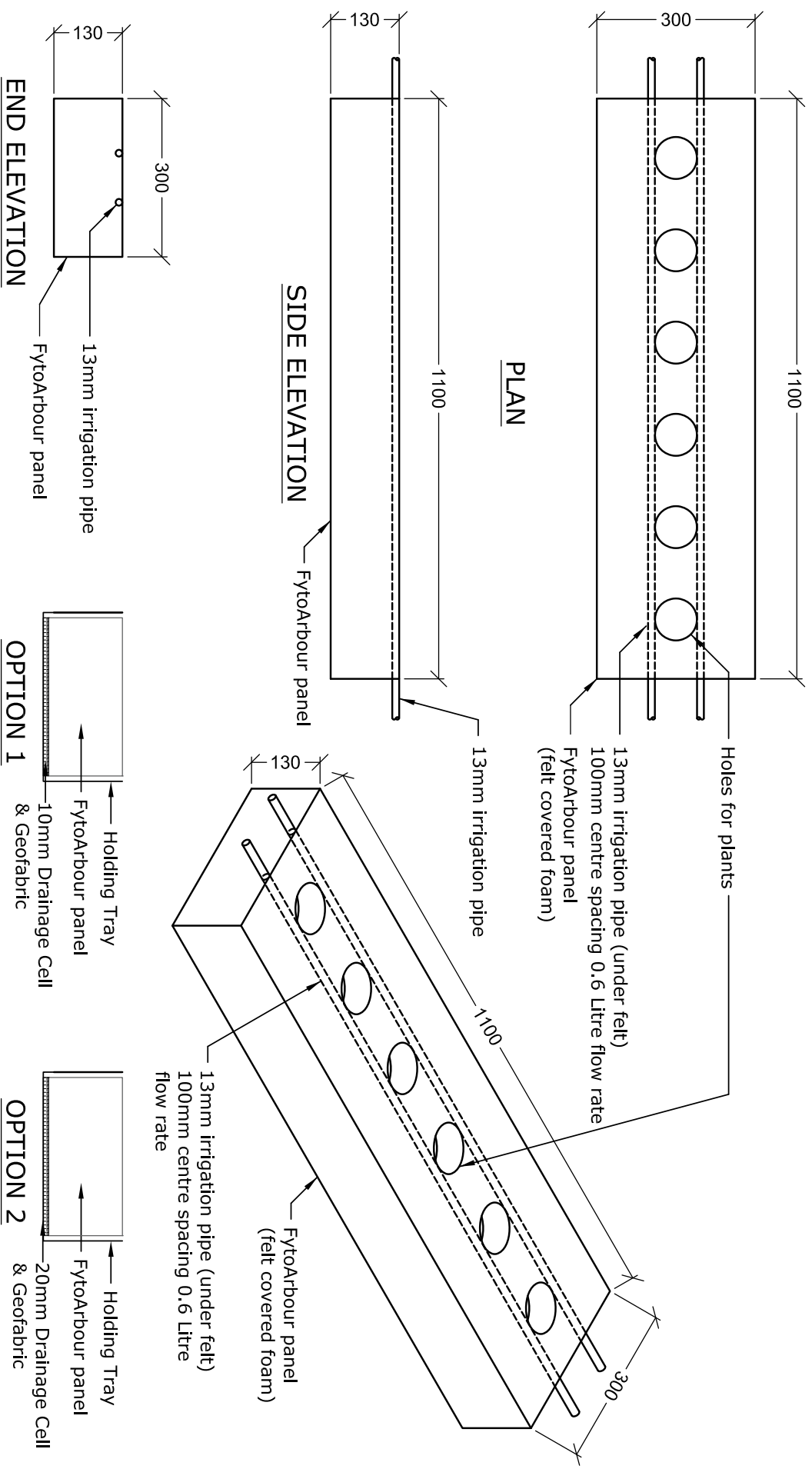

Project Title: FYTOARBOUR - 1100 long x 300 wide x 130 deep		Project Number	
Typical Details		Drawn By: MC	
Date: 17/09/20	Drawing No: FA-002	Revision: A	Checked By: GH
FYTOARBOUR - STANDARD TYPE #2		SATURATED WEIGHT INCLUDING PLANTS: 35kg/LM	
<p>FytoGreen <small>Specialists in the Best Environment</small> SPECIALISTS IN: GREEN BUILDINGS, SLOW GROWING FytoGreen Australia Pty. Ltd. ABN: 20 099 581 736 3 Witches Lane, Sorrento VIC 39112 ph: 1300 182 341 fax: +61 3 5978 0744 E: info@fytoGreen.com.au www.fytoGreen.com.au</p>			
Scale: 1:10	Rev	Date	Description

All dimensions and loads must be checked on site and not scaled from the drawing.
 This drawing is subject to copyright and must not be reproduced or used in any other form without prior
 written permission. Images shown are indicative only and may vary slightly from actual appearance.

FYTOARBOUR - STANDARD TYPE #3

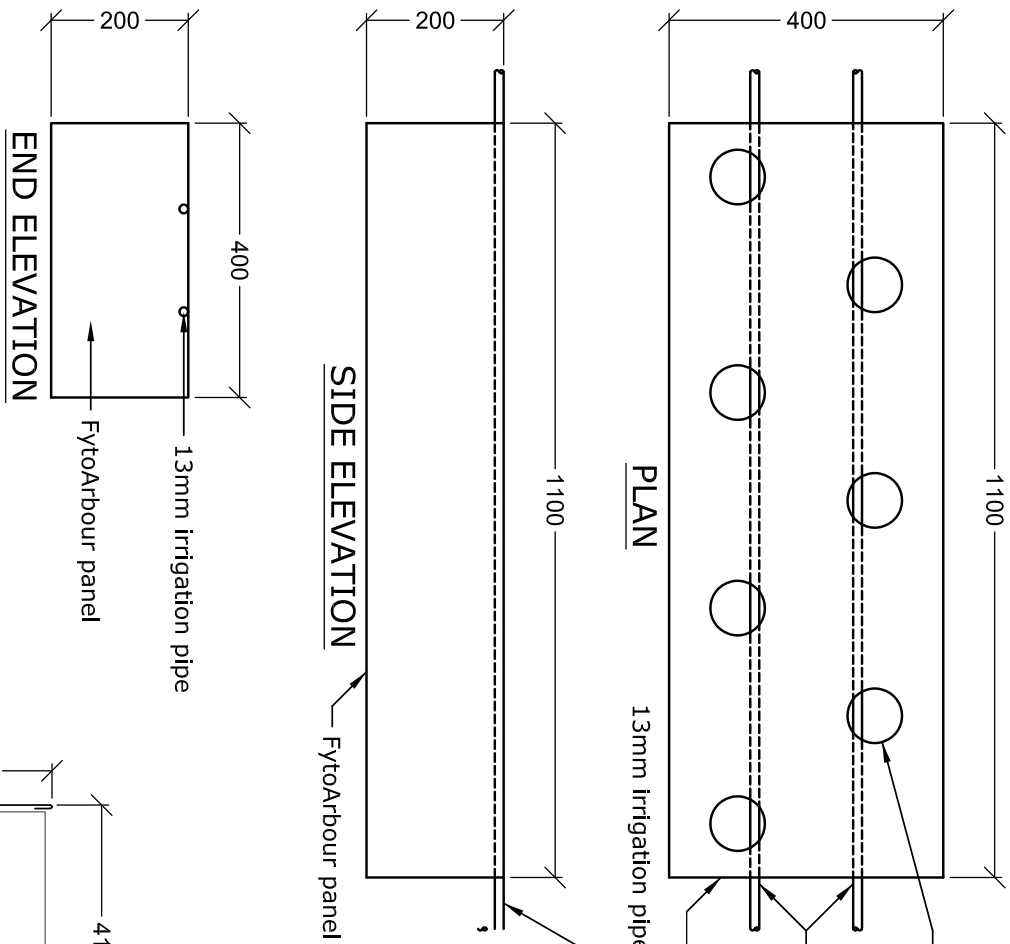

- HOLDING TRAY MATERIALS:**
- COLORBOND (REQUIRES STIFFENING FOLD)
 - ALUMINUM
 - ZINCALUME
 - STAINLESS STEEL

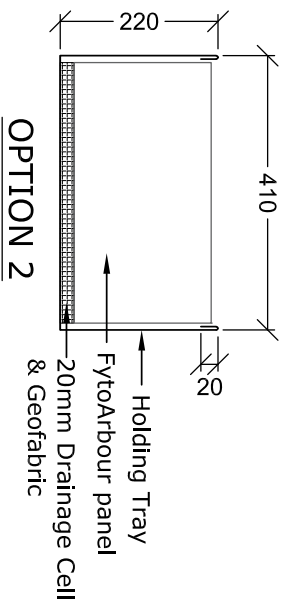
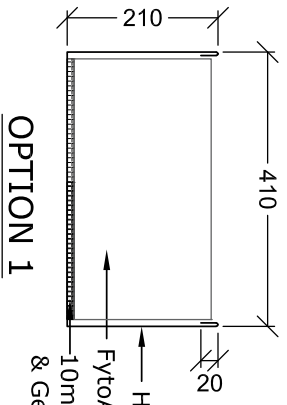
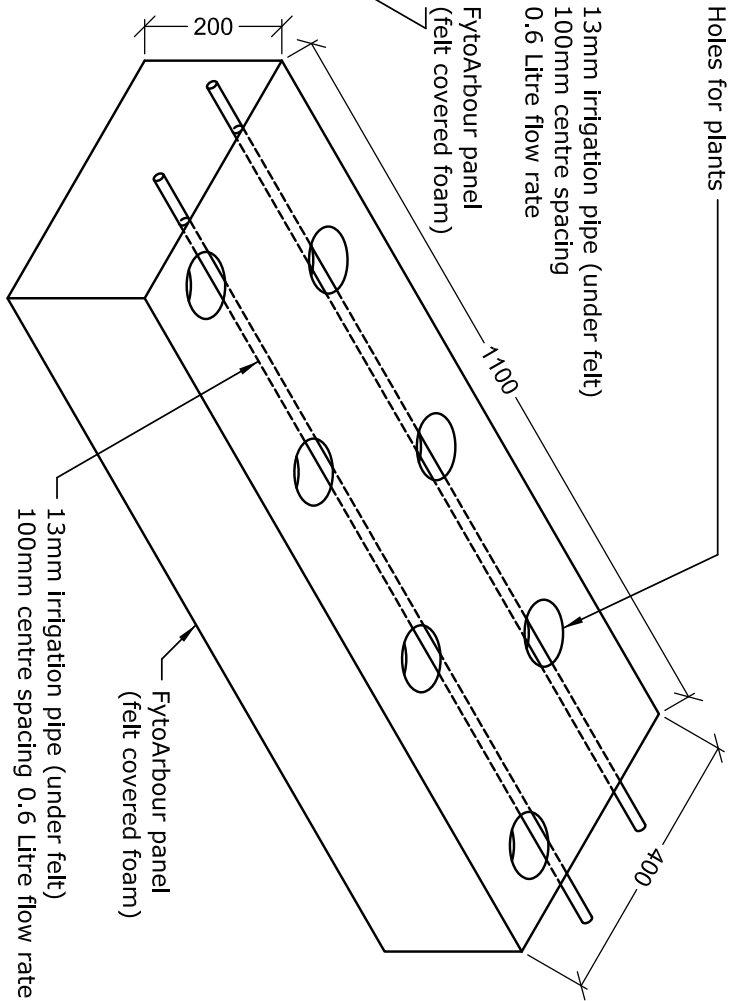

Project Title: FYTOARBOUR - 1100 long x 400 wide x 200 deep		Project Number	
Date: 24/09/20		Drawing No: FA - 003	
Revision: A		Revision: A	
Scale: 1:10		Rev	
Description: SATURATED WEIGHT INCLUDING PLANTS: 56kg/LM		Date	
FYTOARBOUR - STANDARD TYPE #3		Description	
<p>FytoGreen Australia Pty. Ltd. ABN 20 099 581 736 3 Witches Lane, Somersville, VIC 39112 ph: 1300 182 341 fax: +61 3 5978 0744 E: info@fytoGreen.com.au www.fytoGreen.com.au</p>		Project Number Drawn By: MC Checked By: GH	

All dimensions and loads must be checked on site and not scaled from the drawing. This drawing is subject to copyright and must not be reproduced or used in any other form without prior written permission. Images shown are indicative only and may vary slightly from actual appearance.

FYTOARBOUR - STANDARD TYPE #4

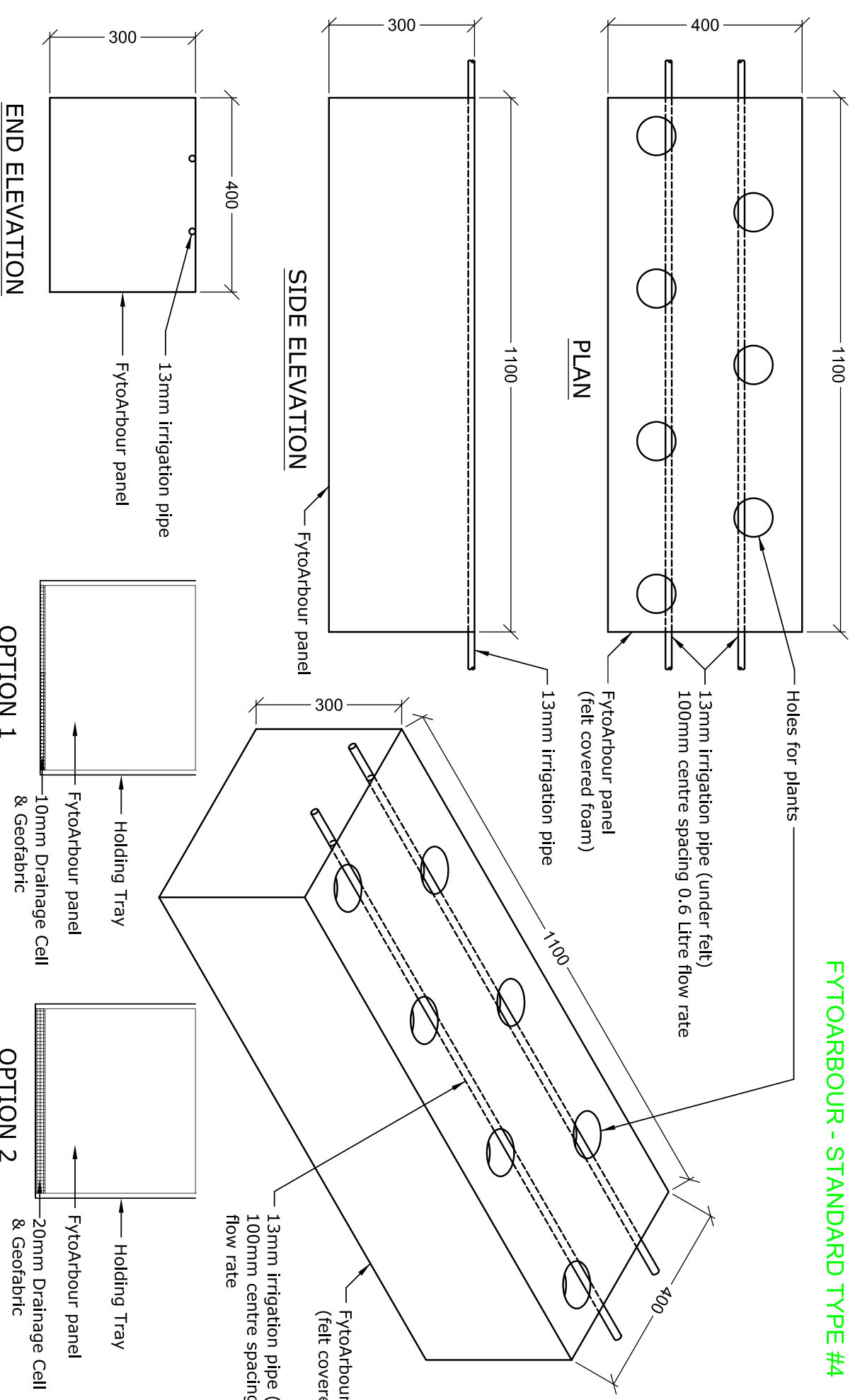

Project Title: FYTOARBOUR - 1100 long x 400 wide x 300 deep		Project Number:	
Typical Details		Drawn By: MC	
Date: 17/09/20	Drawing No: FA - 004	Checked By: GH	
Revision: A			
SATURATED WEIGHT INCLUDING PLANTS: 84kg/LM			
Rev	Date	Description	
		FYTOARBOUR - STANDARD TYPE #4	
		SATURATED WEIGHT INCLUDING PLANTS: 84kg/LM	
FYTOARBOUR - STANDARD TYPE #4		FYTOARBOUR - STANDARD TYPE #4	
SATURATED WEIGHT INCLUDING PLANTS: 84kg/LM		SATURATED WEIGHT INCLUDING PLANTS: 84kg/LM	
<p>FytoGreen Australia Pty. Ltd. ABN 20 099 581 736 3 Witches Lane, Somersville, VIC 3912 ph: 1300 182 341 fax: +61 3 5978 0744 E: info@fytoGreen.com.au www.fytoGreen.com.au</p>			

Scale: 1:10

All dimensions and levels must be checked on site and not scaled from the drawing.
 This drawing is subject to copyright and must not be reproduced or used in any other form without prior written permission from FytoGreen.
 Images shown are indicative only and may vary slightly from actual appearance.

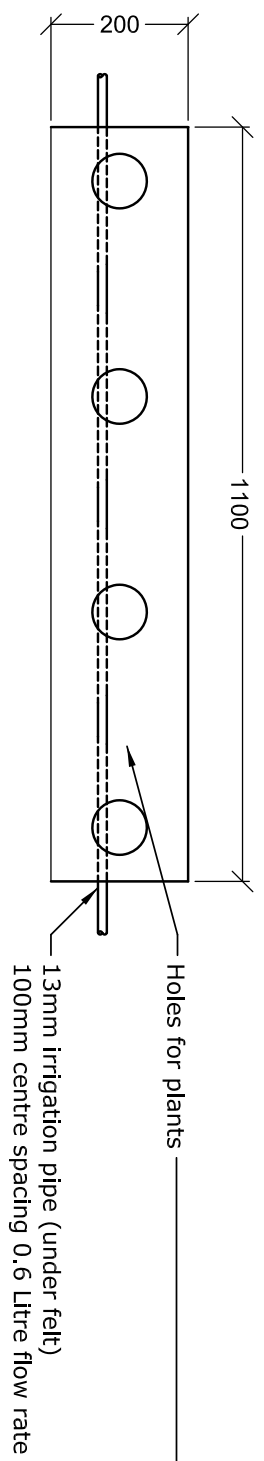

PLAN

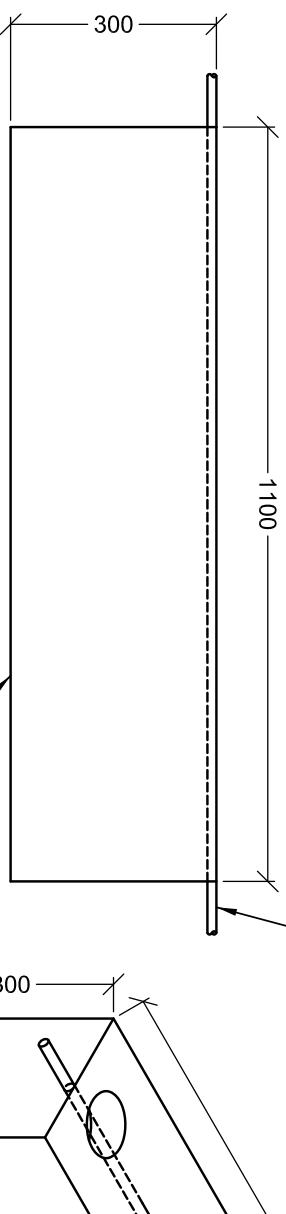

SIDE ELEVATION

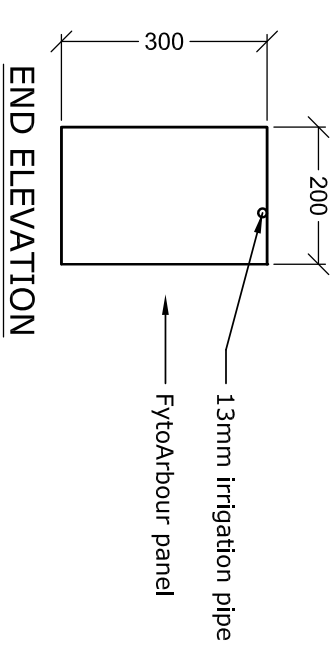

END ELEVATION

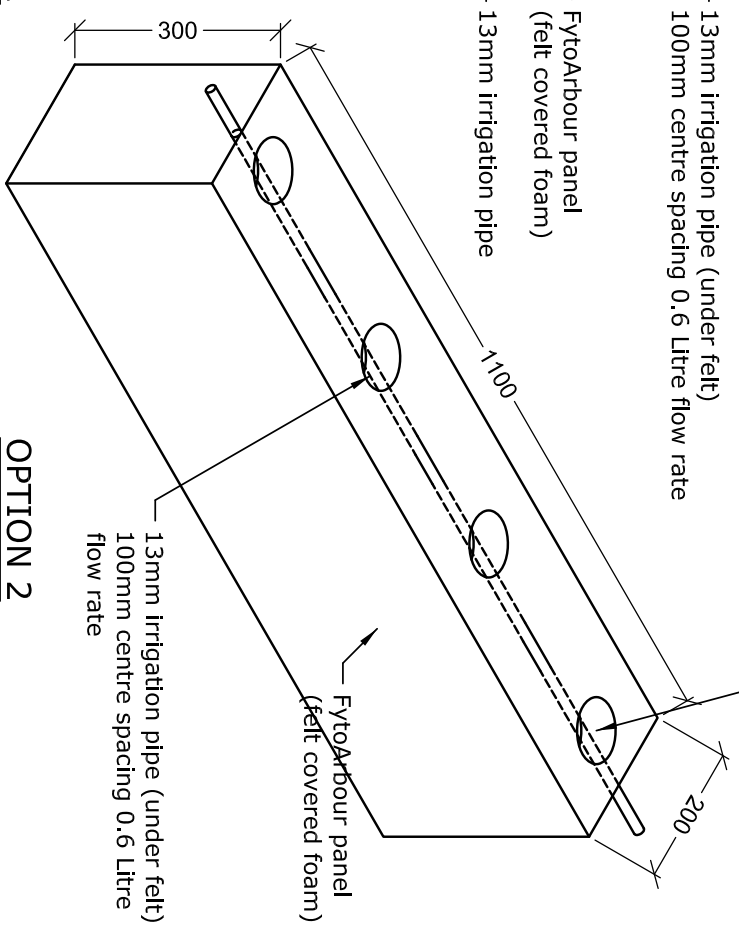

OPTION 1

OPTION 2

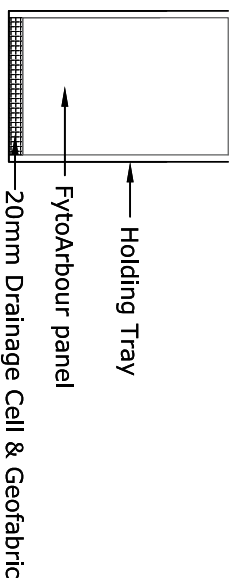
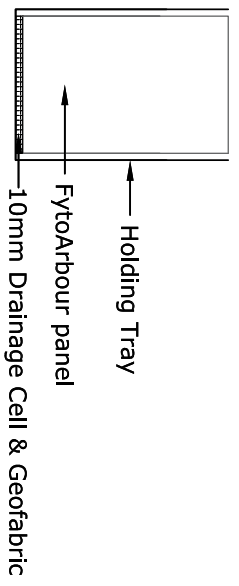

Project Title: FyTOARBOR - 1100 long x 200 wide x 300 deep	
TYPICAL DETAILS	
Date: 16/09/20	Drawing No: FA - 005
Revision:	
Scale: 1:10	

Rev	Date	Description
		FyTOARBOR - STANDARD TYPE #5
		SATURATED WEIGHT INCLUDING PLANTS: 42kg/LM

FytoGreen
 SPECIALIST QUANTITIES, GREEN PLANTERS, SOIL SOLUTIONS
 FytoGreen Australia Pty. Ltd. ABN 20 099 581 736
 3 Wards Lane, Somersville, VIC 39112
 ph: 1300 182 341 fax: +61 3 5978 0744
 E: info@fytoGreen.com.au www.fytoGreen.com.au

Project Number	Drawn By: MC
	Checked By: GH

All dimensions and loads must be checked on site and not scaled from the drawing.
 This drawing is subject to copyright and must not be reproduced or used in any other form without prior
 written permission. Images shown are illustrative only and may vary slightly from actual appearance.



FytoArbour Cascading Species

Fytogreen pride itself in provide Bespoke greening solutions, specifically tailor made to site conditions.

The following are a selection of cascading species Fytogreen has available for our FytoArbour ssystem.

Please be aware that this is a guide only and all species would be combined with site specific non-cascading species, as companion planting is key to producing sustainable greening solutions.



Ceropogia woodii

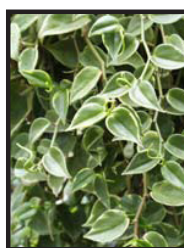

Peperomia scandens



Syngonium batik



Begonia fragrant beauty



Syngonium podophyllum green



Columnea microphylla





**Senecio
rowleyanus**

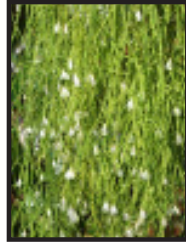

**Rhipsalis
compos
portoana**



**Rhipsalis
baccifera**



**Aeschynanthus
speciosus**



**Rhipsalis
pentaptera**

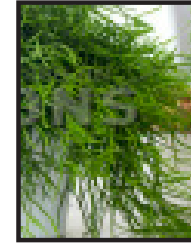

**Rhipsalis teres
f. heteroclada.**



**Philo
hederaceum**



**Rhipsalis
goebeliana.**

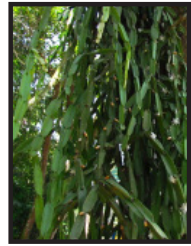

**Rhipsalis
paradoxa**



**Philo
bipennifolium**



**Rhipsalis
pacheo-leeri.**



**Epiphyllum
anguliger**



**Monstera
adansonii**



**Epiphyllum
pumilum**



**Epipremum
aureum**



Bespoke Ecological Sustainable Greening Solutions

The standard Fytogreen range includes...



FytoWall

A soil-less panel vertical garden system suitable for commercial indoor and outdoor applications.



FytoFelt

A pocket green wall system suitable for commercial and residential projects Available as design / install or DIY.



FC FytoFelt

A fire-compliant (AS1530.3-1999) pocket system green wall system for indoor or outdoor applications.



3d Gardening

Curved walls, columns or double sided oscillating FytoBlades. We can create virtually any BESPOKE sizing.



FytoArbour

Ultra-lightweight, self-contained hydroponic garden that can be mounted above the ground.

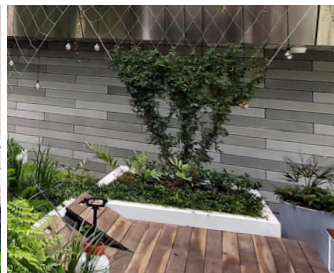

Green Facades

Cost-effective vertical greening utilizing climber and creeper plants on wires and cables.



Pre-Grown Green Facades

This system provides great foliage cover at installation, instead of waiting up to 2-3 years for coverage.



Roof Gardens

Intensive, Extensive and sloping sustainable living roofs for residential and commercial projects.



Architectural Planter Boxes

Fire Compliant Aluminum, LLDPE, or GRC. Planter boxes are UV stable, stylish, versatile and cost effective.



Custom Planter Boxes

Fytogreens extensive range of custom planter boxes are suitable for nearly any indoor or outdoor application.



Floating Wetlands

Designed to vegetate water bodies for aesthetics, water clarification, safe habitat or water rehabilitation.



Horticultural Maintenance

Our specialist elevated horticultural maintenance service is recommended for all our unique greening projects.

Fytogreen also offers a unique capability to design and create tailor made bespoke greening solutions to suit your projects needs.

Fytogreen work collaboratively with our clients; home owners, architects, landscape architects or project consultant teams, utilizing our extensive technical know-how to deliver unique, sustainable greening solutions to fit any project vision.

Offering the widest range of greening solutions on the market, with multi-dimensional systems that increase the diversity, quantity & density of biophilic design and the capability and industry know-how to create brand new solutions when required.

Fytogreen Australia Greening the Built Environment

www.fytogreen.com.au

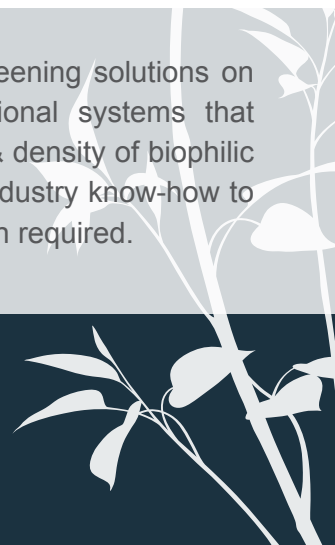

FOR MORE INFORMATION CONTACT:

Fytogreen Australia Pty Ltd

3 Webbs Lane, Somerville, Victoria, 3912

Ph: 1300 182 341

Email: info@fytogreen.com.au



www.fytogreen.com.au





Fytogreen is leading the industry, delivering a Australian made pocket green wall solution providing maximum quality, sustainability and water efficiency

Fytogreen's Fytofelt pocket system is fully Australian made and has been fabricated with Fytogreen's years of experience within the industry.

Our quality vertical garden pockets provide a safe growing medium, that is pH neutral and allows roots to grow directly into the felt, creating a stable growing environment that allows all plants to be watered evenly and not constrained in any way.

The felt pockets are made from a fire compliant felt that is extremely tough and provides perfect growing conditions for a range of plant species.

Additionally, the plants root system is wrapped with felt wraps; allowing you to create an interchangeable design with the possibility of simple plant replacement and re-arranging anywhere within the wall.

Fytogreen's pocket green wall system is perfect for both commercial and residential installations, comes individually designed, pre-grown, installed and maintained by Fytogreen or packaged for DIY installation.

The panels are available in a large range of module sizes.

Why choose FC-Fytofelt

Fytogreen is leading the industry, delivering a fire compliant green wall solution for maximizing safety.

We are proud to offer our recently adapted, Australian made vertical garden - a sustainable green wall pocket system compliant to be AS1530.3-1999

WHAT THIS MEANS TO YOU, THE CLIENT

- Fytogreen can offer AS1530.3-1999 fire compliant green wall system for commercial and residential builds.
- This green wall system has a non-combustible aluminum backing board and our new felt is compliant to AS1530.3 testing standards.
- Fytogreen's new FC-Fytofelt green wall system has the capabilities to use less water. The FC-Fytofelt ensures all plants are watered uniformly with improved water absorption properties within the felt by a factor of 2, ensuring improved buffering.
- The plants root system is wrapped with fire compliant wraps; this creates an interchangeable system, allowing the possibility of simple plant re-arranging or replacement anywhere on the wall.
- Available in a large range of module sizes.



An Australian Made, Sustainable, Fire Compliant Green Wall System



Fytogreen's pocket green wall system has been successfully installed indoors and outdoors on over 1,700m² across Australia.



Greening the Built Environment
VERTICAL GARDENS . GREEN FACADES . ROOF GARDENS

WORK BY OTHERS

Host Wall Waterproofing

(To be completed prior to Fytogreen commencing works)

WORKS BY FYTOGREEN

- Hooks
- Irrigation
- Designed, pre-planted & fixed Fytowall Panels
- Irrigation and Fertilization Control Box
- Drip tray - optional
- Maintenance

Fytogreen Fytofelt pocket green wall system is custom made to suit any size green wall, indoors or outdoors.

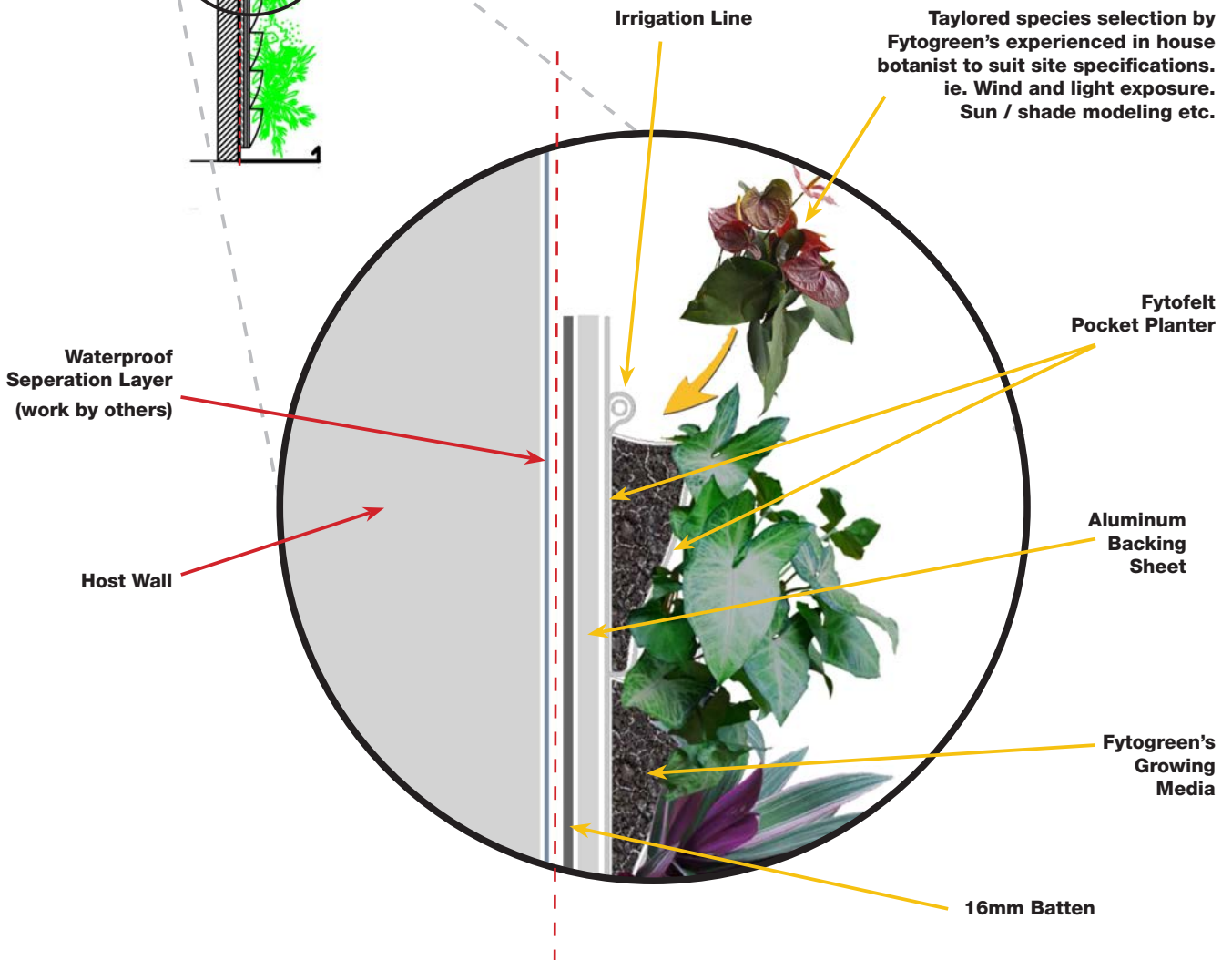

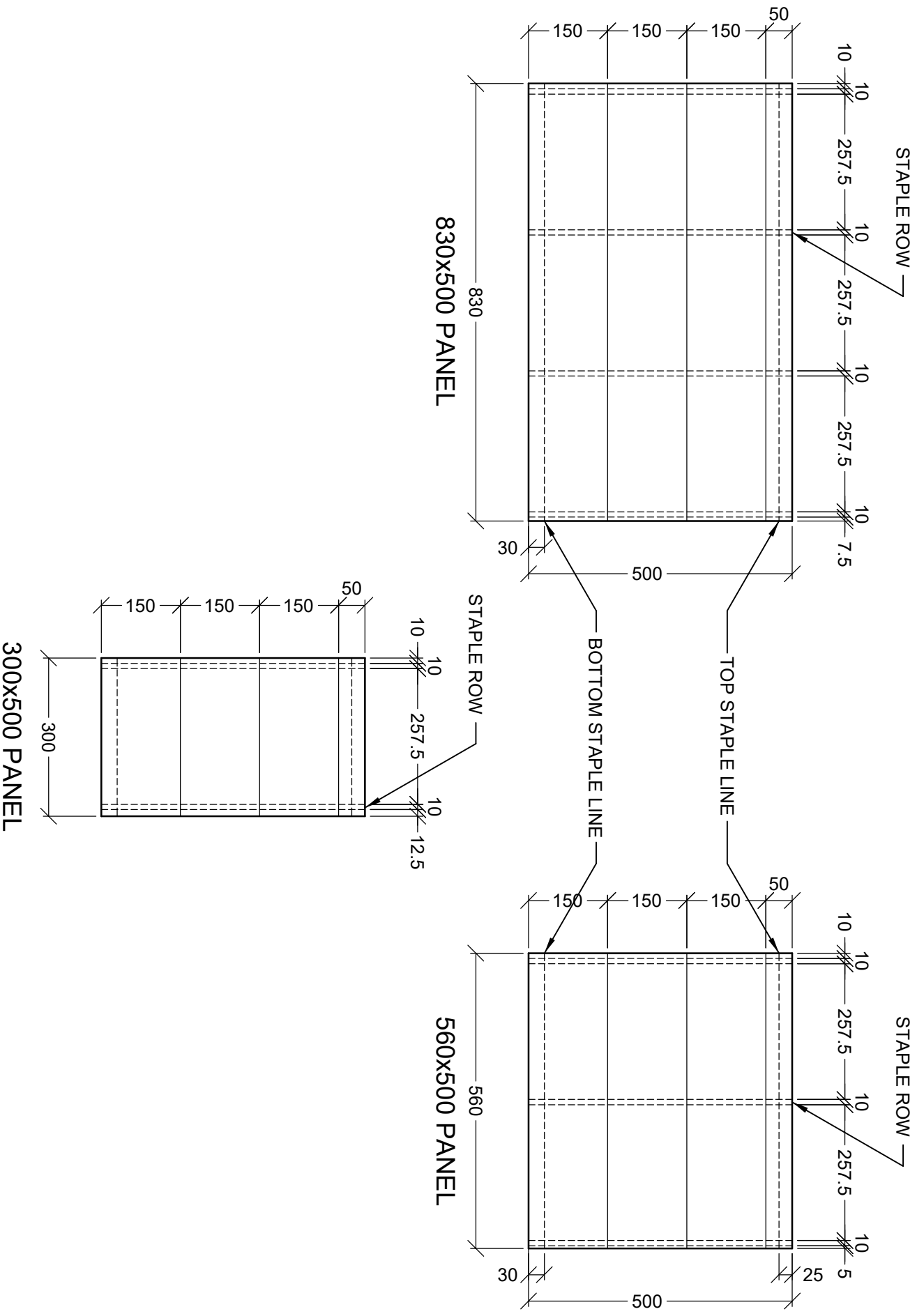

Project/Title: FC_FYTOFELT - 830X500, 560X500 & 300X300 PANELS		
Date: 29/01/20	Drawing No: 001	Revision:
<small>All dimensions and details must be checked on site and not relied from this drawing. This drawing is subject to copyright and must not be reproduced or used in any other form without prior written permission from Fyotgreen Australia Pty Ltd. Any reuse of this drawing without the written permission of Fyotgreen Australia Pty Ltd. may result in legal action.</small>		

Rev	Date	Description

Fyotgreen
Shaping the Built Environment
VERTICAL GARDENS · GREEN FACADES · ROOF GARDENS

Fyotgreen Australia Pty. Ltd. ABN. 20 099 581 736
3 Webbs Lane, Somerville, VIC 3912
ph. 1300 182 341 fax. +61 3 5978 0744
E. info@fyotgreen.com.au www.fyotgreen.com.au

Project Number

Drawn By: N.M.

Checked By: G.H.

IRRIGATION
PIPE LOOP

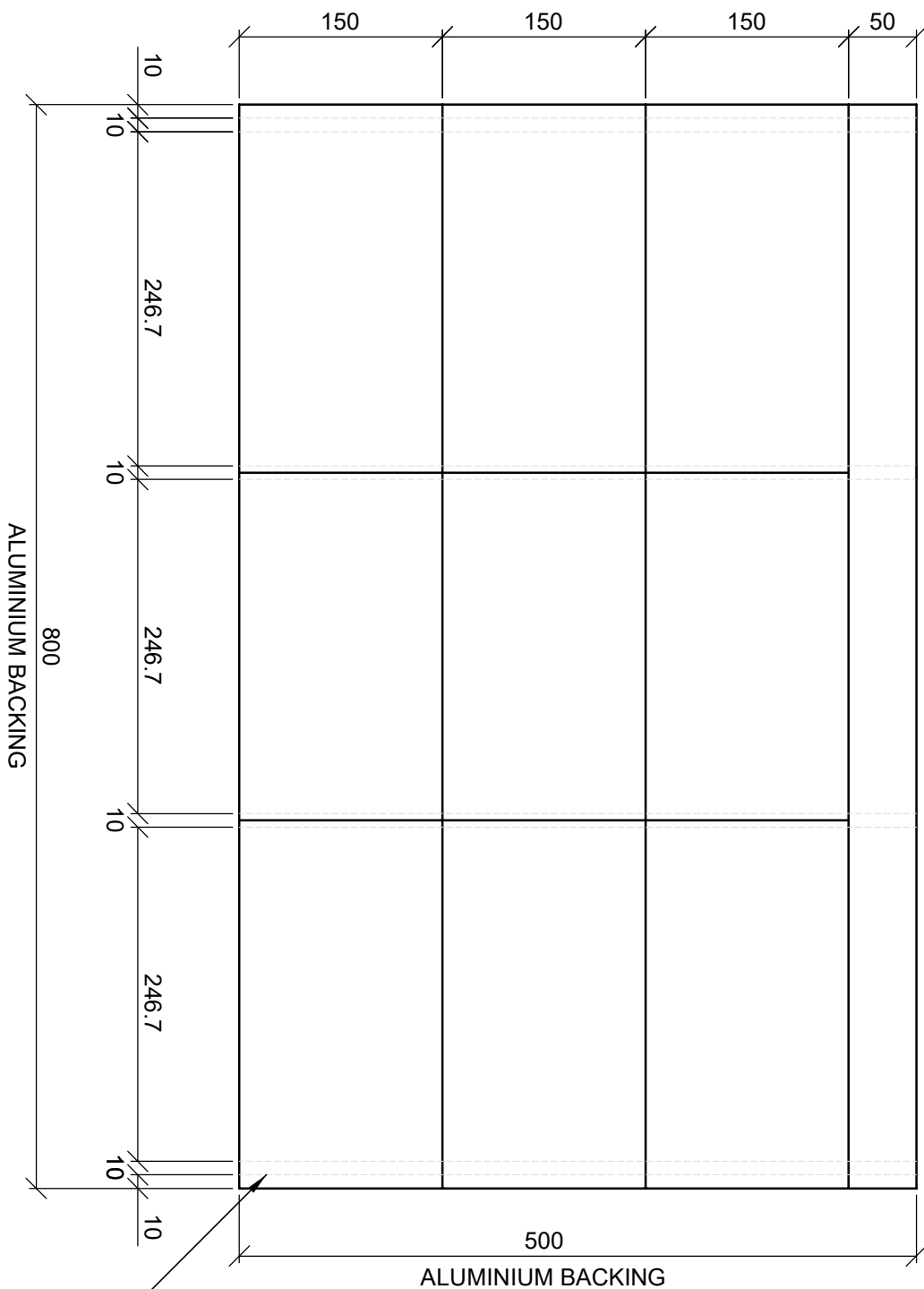

FRONT ELEVATION

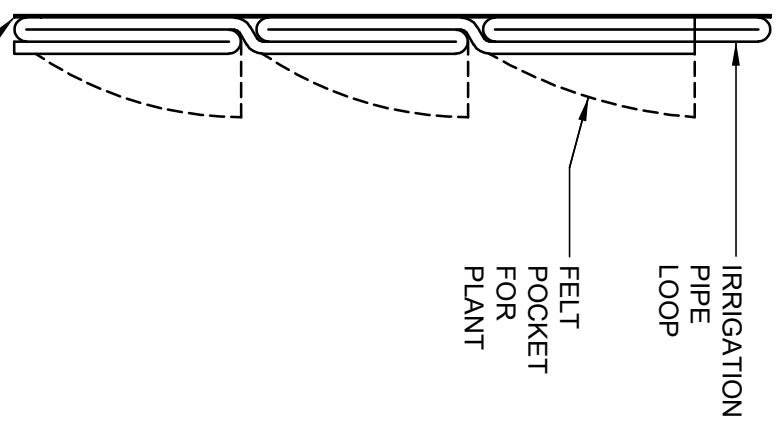

SECTION

Project/Title: FC FYTOFELT - 800 x 500 TYPICAL DETAILS - SHEET 1 of 2	
Date: 02/06/20	Drawing No: FCF- 001
Revision:	
Scale: 1:5	

Rev	Date	Description

FYTOGREEN
Sustaining the Built Environment
VERTICAL GARDENS · GREEN FACADES · ROOF GARDENS

FytoGreen Australia Pty. Ltd. ABN. 20 099 581 736
3 Webbbs Lane, Somerville, VIC 3912
ph. 1300 182 341 fax. +61 3 5978 0744
E. info@fytoGreen.com.au www.fytoGreen.com.au

Project Number	
Drawn By	
Checked By	

All dimensions and levels must be checked on site and obtained from the drawing writer's permission from FytoGreen Australia Pty Ltd. This drawing is subject to copyright and must not be reproduced or used in any other form without prior written permission from FytoGreen Australia Pty Ltd. Any infringement may result in legal action.

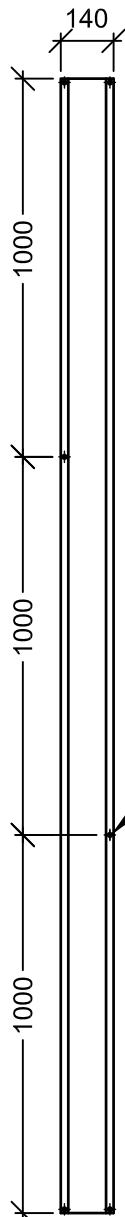

**TOP HAT BATTEN
FRONT ELEVATION**

Scale 1:20

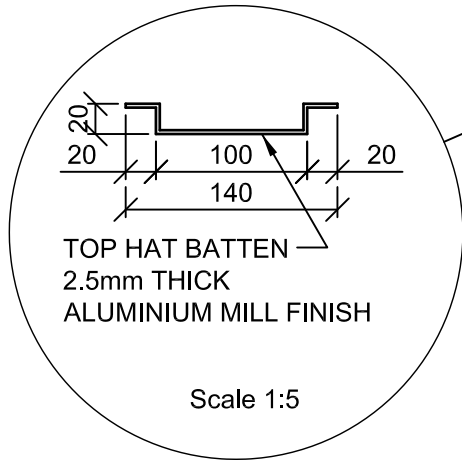

TOP HAT BATTEN
2.5mm THICK
ALUMINIUM MILL FINISH

Scale 1:5

M6 x 50mm CONCRETE SCREW
FIXING TOP HAT BATTEN
TO HOST WALL.

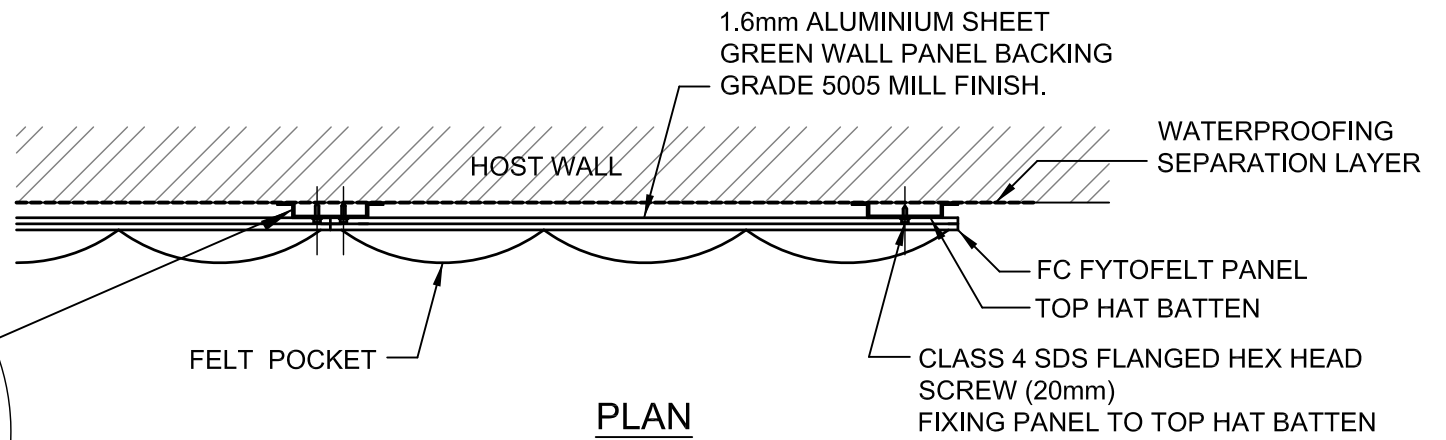

PLAN

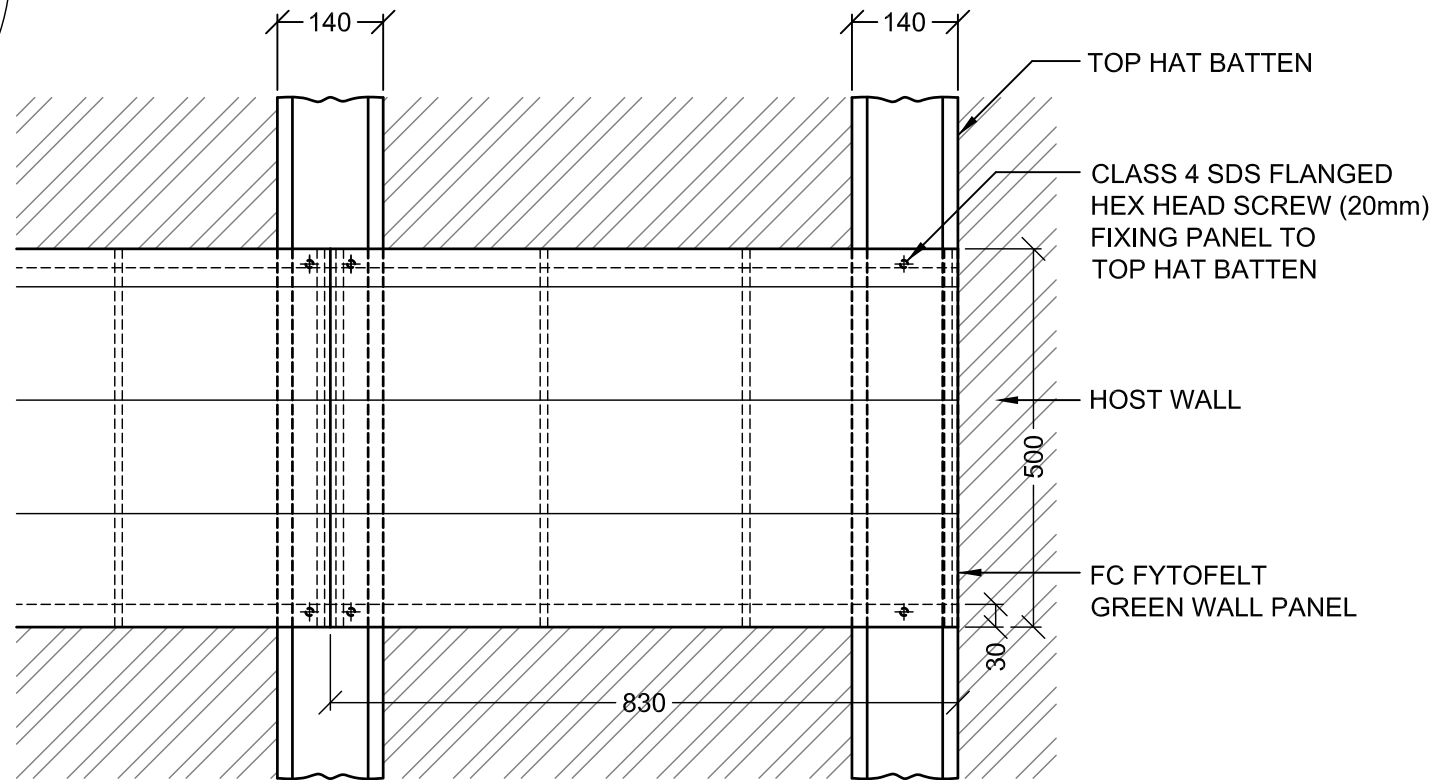

FRONT ELEVATION

Scale 1:10

Project/Title: FC FYTOFELT 830 x 500 PANEL FIXING DETAILS		
Date: 03/01/20	Drawing No: FCF/001	Revision:
Scale: AS SHOWN	All dimensions and levels must be checked on site and not scaled from this drawing. This drawing is subject to copyright and must not be reproduced or used in any other form without prior written permission from Fytogreen Australia Pty Ltd. Images shown are indicative only and may vary slightly from actual appearance.	

Rev	Date	Description

Fytogreen
Greening the Built Environment
VERTICAL GARDENS · GREEN FACADES · ROOF GARDENS
Fytogreen Australia Pty. Ltd. ABN. 20 099 581 736
3 Webbs Lane, Somerville, VIC 3912
ph. 1300 182 341 fax. +61 3 5978 0744
E. info@fytoogreen.com.au www.fytoogreen.com.au

Project Number
Drawn By N.M
Checked By G.H

TYPICAL

Facade Construction

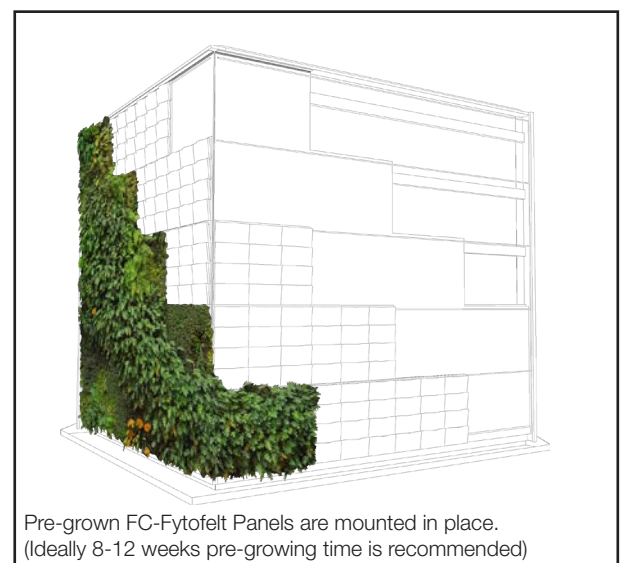
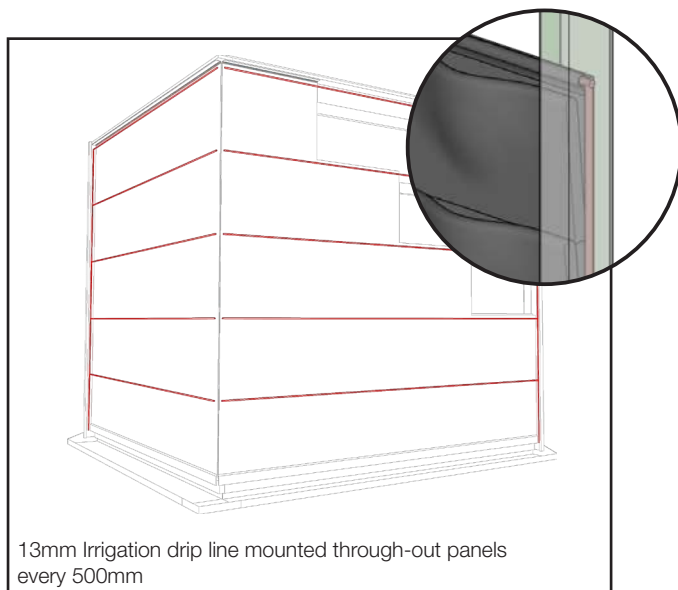
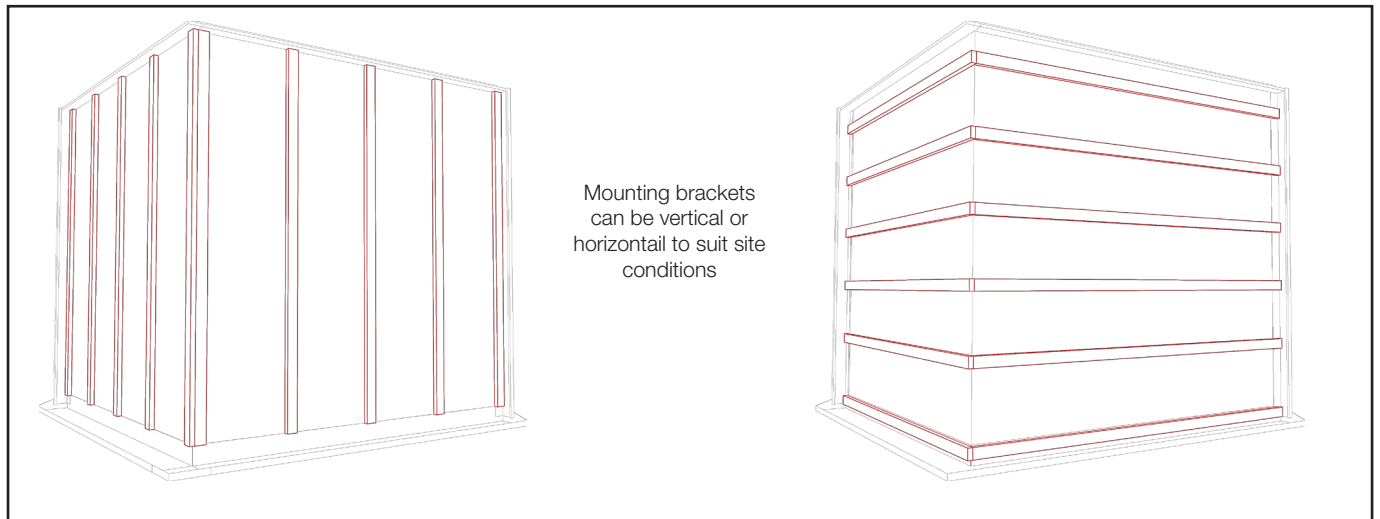
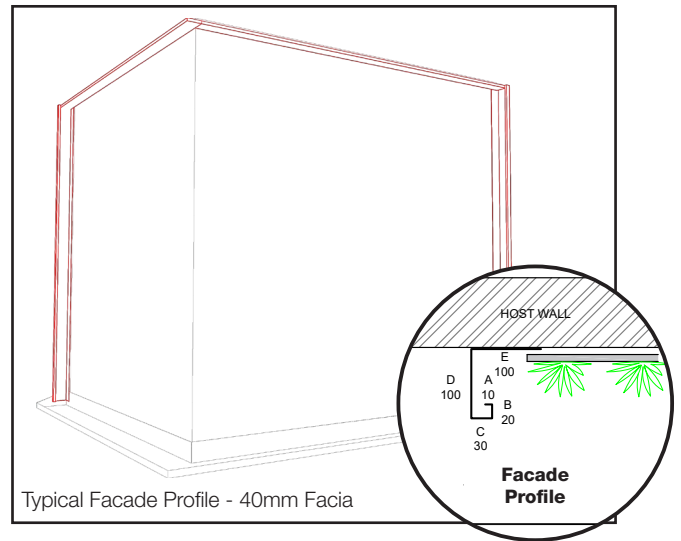
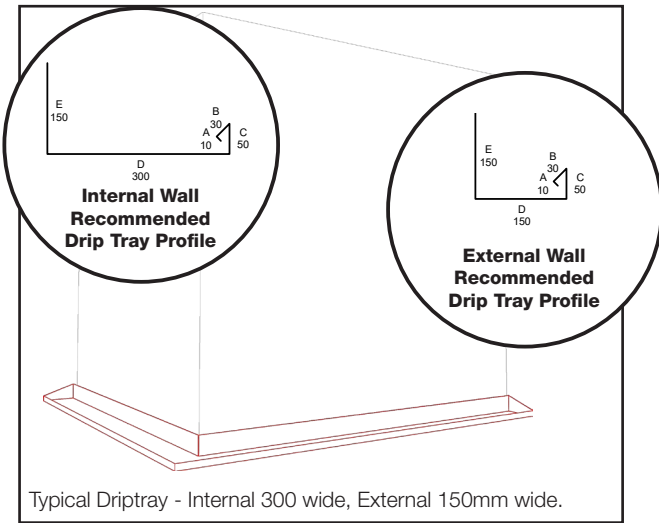



BEYOND INSTALLATION

Maintaining your Vertical Garden

Fytogreen provide a specialist 'elevated' horticultural maintenance department to maintain vegetation, monitor irrigation and fertigation ensuring perfect nutrient balancing and water quality.

The maintenance of our unique installations require specialist plant-based knowledge and experience.

This is specific Fytogreen technology and is incomparable to general garden or indoor plant maintenance.

Maintaining Fytogreen gardens requires close consultation between the botanist and maintenance technicians. This ensures the diversity is preserved, whilst continuing to improve sustainability and plant specific integration, allowing for improved design and reduced maintenance input.

The Fytogreen maintenance division is a group of passionate technicians, who regularly communicate to advance the divisions' internal skill base. The team utilize techniques and materials to maintain Fytogreen's extensive range of projects.

Fytogreen's designers ensure consideration is given to key components of site related variables; such as light, wind and temperature to determine their plant species selections. Non-terrestrial (non typical garden species) are frequently chosen to offer highly adapted traits to maximize success on the vertical plane. Eg. The use of epiphytes and lithophytes species.

Our unique gardens should ONLY be maintained by a specialist, trained in elevated horticulture care. They remotely monitor irrigation, conduct standard on-site water quality checks, nutrient balancing, salt accumulation and pH management.

Our specialized garden systems are not merely plants bolted to walls, they are water and air purifiers, In many cases, providing valuable urban ecological, thermal and acoustic insulation benefits. They are highly specific ecosystems. They address a significantly diverse range of functionalities in support of architecture, built within our populated stressed urban climates.

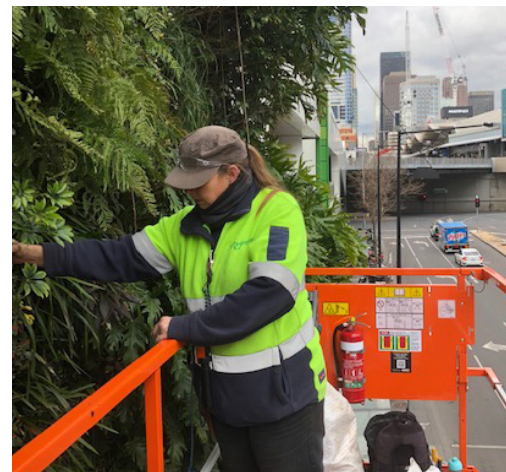
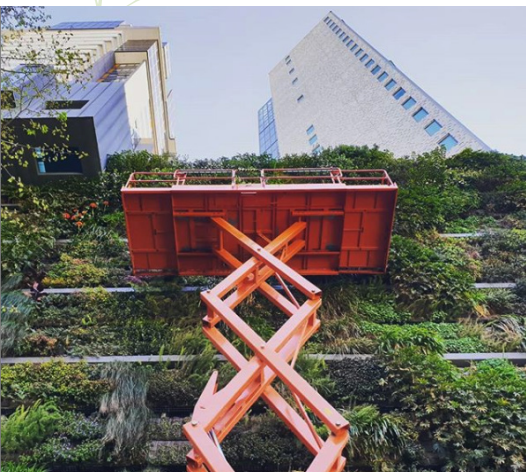

Who are Fytogreen?

TALENTED EXPERIENCED PEOPLE COMMITTED TO CLIENT SERVICE

The team at Fytogreen assist Australian and international developers, architects and landscape architects seeking to create beautiful, environmentally sustainable gardens integrated into built structures.

Fytogreen is Australia's leading specialist in sustainable vertical gardens, environmental extensive roof gardens, light-weight intensive roof gardens, planter boxes and green facades. Fytogreen are also the largest supplier to the roof garden industry in Australia with our unique roof garden system products.

Our History... A TRACK RECORD OF SUCCESS

Fytogreen Australia Pty Ltd was founded in February 2002, when the company became the established licensee in Australia, following on from 23 years of development by Fytogreen originators in Europe.

Over the past 17 years, Fytogreen has become the industry leader & innovator in horticultural technologies. We are a research focused, design & construct supplier of vertical gardens, roof gardens and green facades & all of Fytogreen's design and project management team has extensive experience in the industry

Fytogreen have completed more than 200 successful vertical garden projects, encompassing over 6,000m² of living walls within Australia and international locations.

Fytogreen have also supplied proprietary roof garden media components to approximately 500,000m² of roof gardens and 52,000m² of design and construct extensive roof gardens throughout Australia. Fytogreen has worked with the majority of Tier 1 and Tier 2 construction builders, either directly or indirectly in the capacity of a sub-contractor.

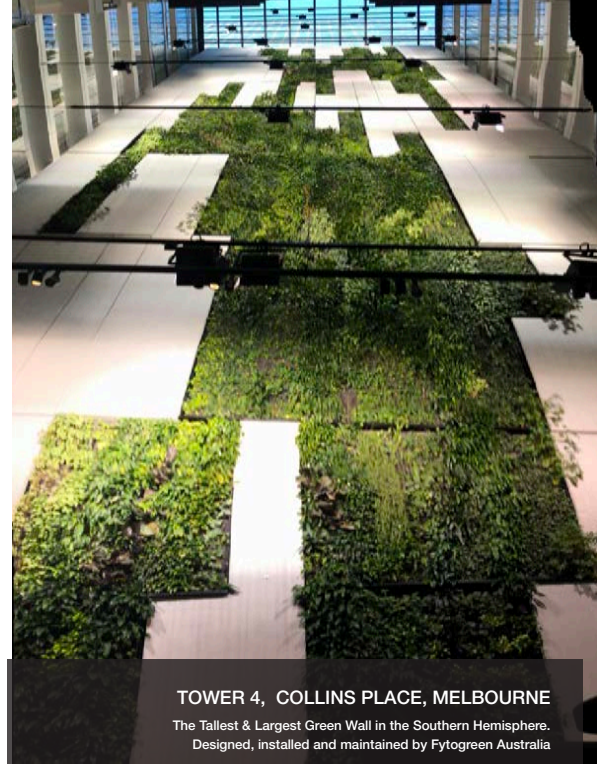

TOWER 4, COLLINS PLACE, MELBOURNE

The Tallest & Largest Green Wall in the Southern Hemisphere.
Designed, installed and maintained by Fytogreen Australia

Our established knowledge library created over many years of collaboration with horticultural experts allows Fytogreen a rapid interchange of experience, problem solving, commercial and technical know-how, which has greatly enhanced our effectiveness and ability to service our clients' needs.

Fytogreen is Australia's leading supplier of vertical gardens and green roofs, delivering Australia's tallest indoor greenwall at Tower Four, Collins Square in Melbourne's CBD (pictured above), as well as the largest green roof in the Southern Hemisphere at the Victorian Desalination Project. We have also installed and maintain Australia's 2nd and 3rd largest green wall at 1 Bligh Street, Sydney and 720 Bourke Street, Melbourne.

CLICK HERE TO READ THE FYTOGREEN CAPABILITY BROCHURE

All contents of this document are supplied from extensive years of experience designing and constructing gardens on built structures here in Australia. All technical aspects of this documentation are considered intellectual property of Fytogreen. Therefore disclosure of this information requires written permission from Fytogreen.



Greening the Built Environment
VERTICAL GARDENS . GREEN FACADES . ROOF GARDENS



Fytogreen thrives by working collaboratively with our clients, Architects, Landscape Architects and consultant project teams.

Fytogreens best results are achieved by:

- Developing a thorough understanding of the project vision, site constraints, and local ecology
- Gathering information prior to and during the project period, and ensuring all details are communicated to each team member
- Drawing upon a wealth of in-house and international experience

Fytogreen provides a comprehensive and client focused solution to all projects continuing beyond the traditional scope of the project. The completion of a project does not mean the end of our working relationship.



We are actively engaged in ensuring the long-term sustainability of the gardens, from installation through to our programmed preventative maintenance.

Years of Research and Development leads to Award Winning, Sustainable Garden Designs



Fytogreen Australia Pty. Ltd. ABN. 20 099 581 736
HEAD OFFICE: 3 Webbs Lane, Somerville, VIC 3912
fax. +61 3 5978 0744 E. info@fytogreen.com.au

1300 182 341

www.fytogreen.com.au